

CABLE LADDER ACCESSORIES...

HORIZONTAL ELBOW

RADIUS: 300mm (450mm & 600mm on request)

DIRECTION: 30°, 45°, 60°, 90°

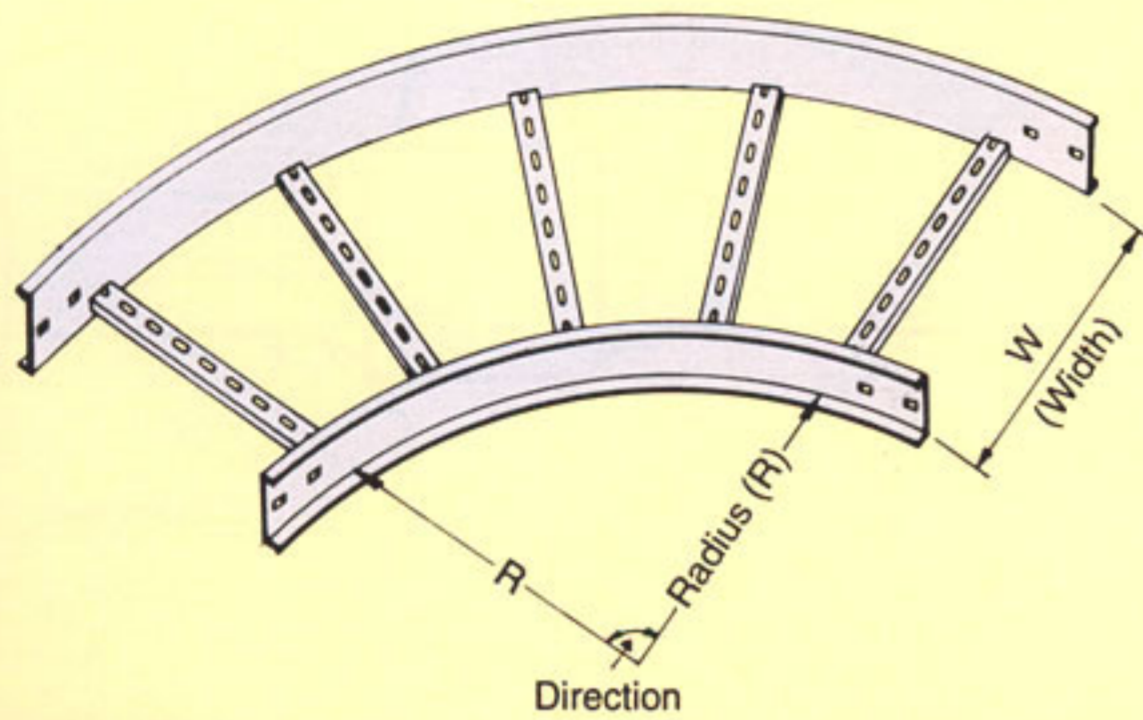

PICTURAL VIEW

SUPPORTS LOCATION RECOMMENDED BY NEMA.

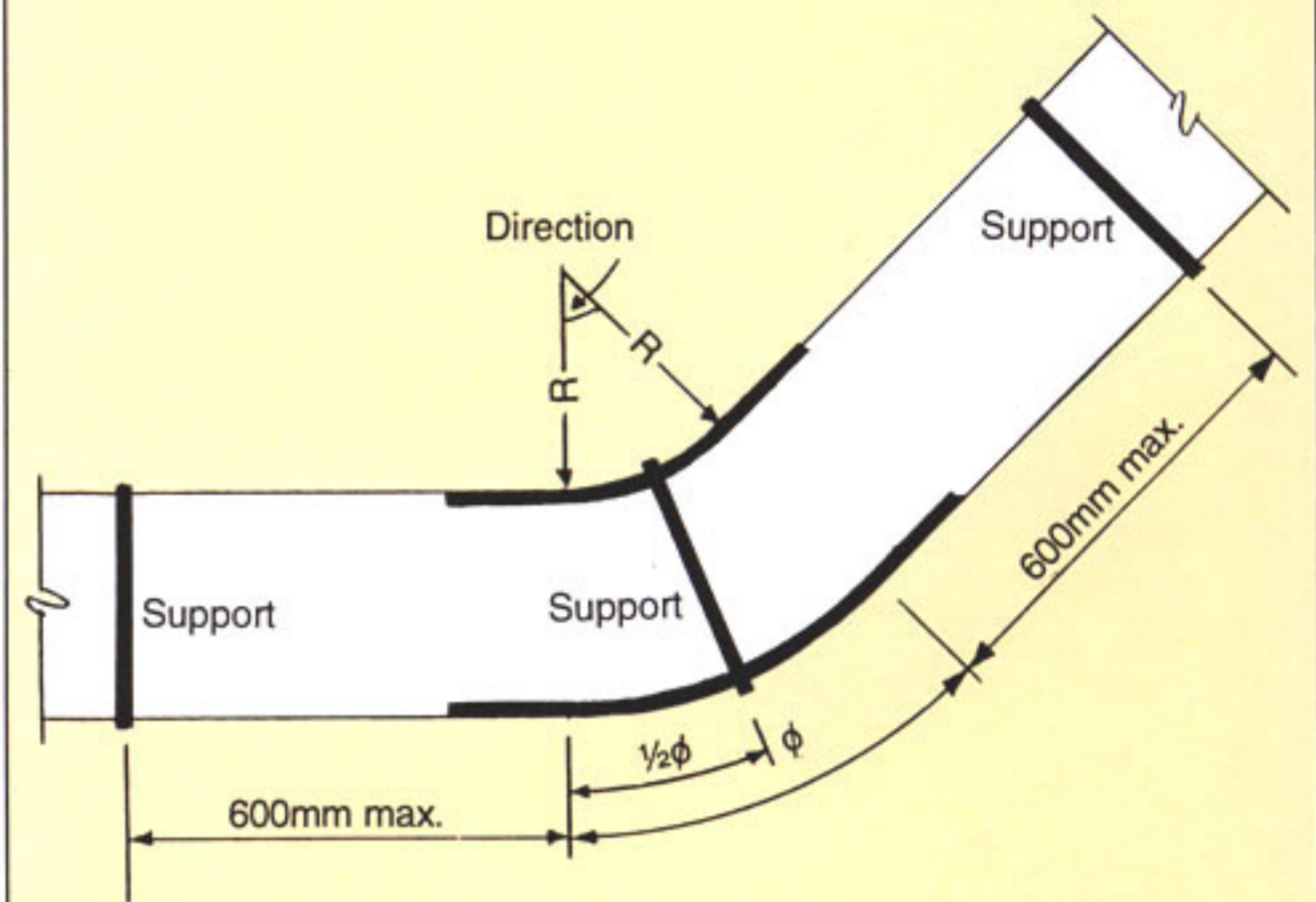

PLAN VIEW

HORIZONTAL ELBOW IN HOT DIP GALVANISED FINISH

ORDERING PART NUMBERS

TYPES	BES-12 Series	BES-16 Series	BES-20 Series	DIRECTION	WIDTH
PART NUMBERS	SHE-12-15W-30D-300R	SHE-16-15W-30D-300R	SHE-20-15W-30D-300R	30°	150mm
	SHE-12-15W-45D-300R	SHE-16-15W-45D-300R	SHE-20-15W-45D-300R	45°	
	SHE-12-15W-60D-300R	SHE-16-15W-60D-300R	SHE-20-15W-60D-300R	60°	
	SHE-12-15W-90D-300R	SHE-16-15W-90D-300R	SHE-20-15W-90D-300R	90°	
Use of Prefix	SHE-12-30W-30D-300R	SHE-16-30W-30D-300R	SHE-20-30W-30D-300R	30°	300mm
	SHE-12-30W-45D-300R	SHE-16-30W-45D-300R	SHE-20-30W-45D-300R	45°	
	SHE-12-30W-60D-300R	SHE-16-30W-60D-300R	SHE-20-30W-60D-300R	60°	
	SHE-12-30W-90D-300R	SHE-16-30W-90D-300R	SHE-20-30W-90D-300R	90°	
a) FOR ALUM FINISH	SHE-12-45W-30D-300R	SHE-16-45W-30D-300R	SHE-20-45W-30D-300R	30°	450mm
	SHE-12-45W-45D-300R	SHE-16-45W-45D-300R	SHE-20-45W-45D-300R	45°	
	SHE-12-45W-60D-300R	SHE-16-45W-60D-300R	SHE-20-45W-60D-300R	60°	
	SHE-12-45W-90D-300R	SHE-16-45W-90D-300R	SHE-20-45W-90D-300R	90°	
use AHE 12 - or AHE 16 - AHE 20 -	SHE-12-60W-30D-300R	SHE-16-60W-30D-300R	SHE-20-60W-30D-300R	30°	600mm
	SHE-12-60W-45D-300R	SHE-16-60W-45D-300R	SHE-20-60W-45D-300R	45°	
	SHE-12-60W-60D-300R	SHE-16-60W-60D-300R	SHE-20-60W-60D-300R	60°	
	SHE-12-60W-90D-300R	SHE-16-60W-90D-300R	SHE-20-60W-90D-300R	90°	
b) FOR STAINLESS STEEL FINISH	SHE-12-76W-30D-300R	SHE-16-76W-30D-300R	SHE-20-76W-30D-300R	30°	760mm
	SHE-12-76W-45D-300R	SHE-16-76W-45D-300R	SHE-20-76W-45D-300R	45°	
	SHE-12-76W-60D-300R	SHE-16-76W-60D-300R	SHE-20-76W-60D-300R	60°	
	SHE-12-76W-90D-300R	SHE-16-76W-90D-300R	SHE-20-76W-90D-300R	90°	
use SSHE 12 - or SSHE 16 - SSHE 20 - and specify grade.	SHE-12-90W-30D-300R	SHE-16-90W-30D-300R	SHE-20-90W-30D-300R	30°	900mm
	SHE-12-90W-45D-300R	SHE-16-90W-45D-300R	SHE-20-90W-45D-300R	45°	
	SHE-12-90W-60D-300R	SHE-16-90W-60D-300R	SHE-20-90W-60D-300R	60°	
	SHE-12-90W-90D-300R	SHE-16-90W-90D-300R	SHE-20-90W-90D-300R	90°	

CABLE LADDER ACCESSORIES...

HORIZONTAL EQUAL CROSS

RADIUS: 300mm (450mm & 600mm on request)

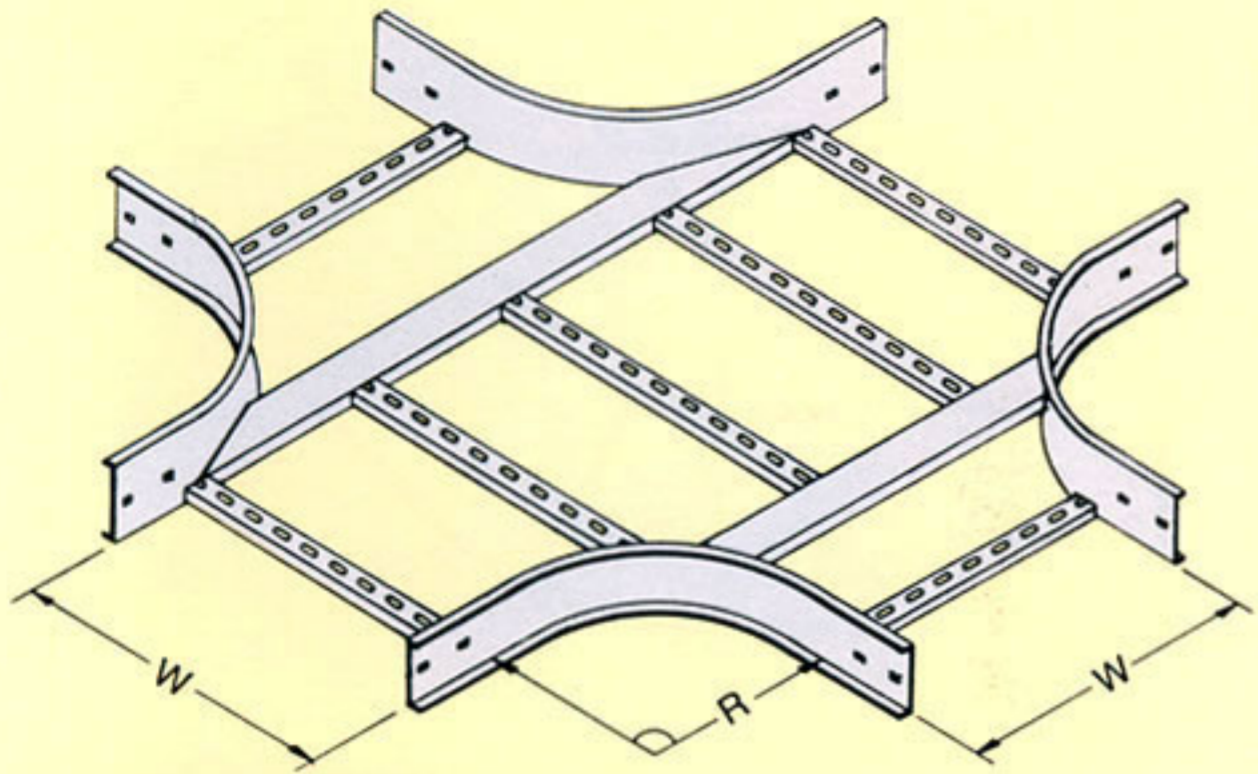

PICTURAL VIEW

SUPPORTS LOCATION RECOMMENDED BY NEMA.

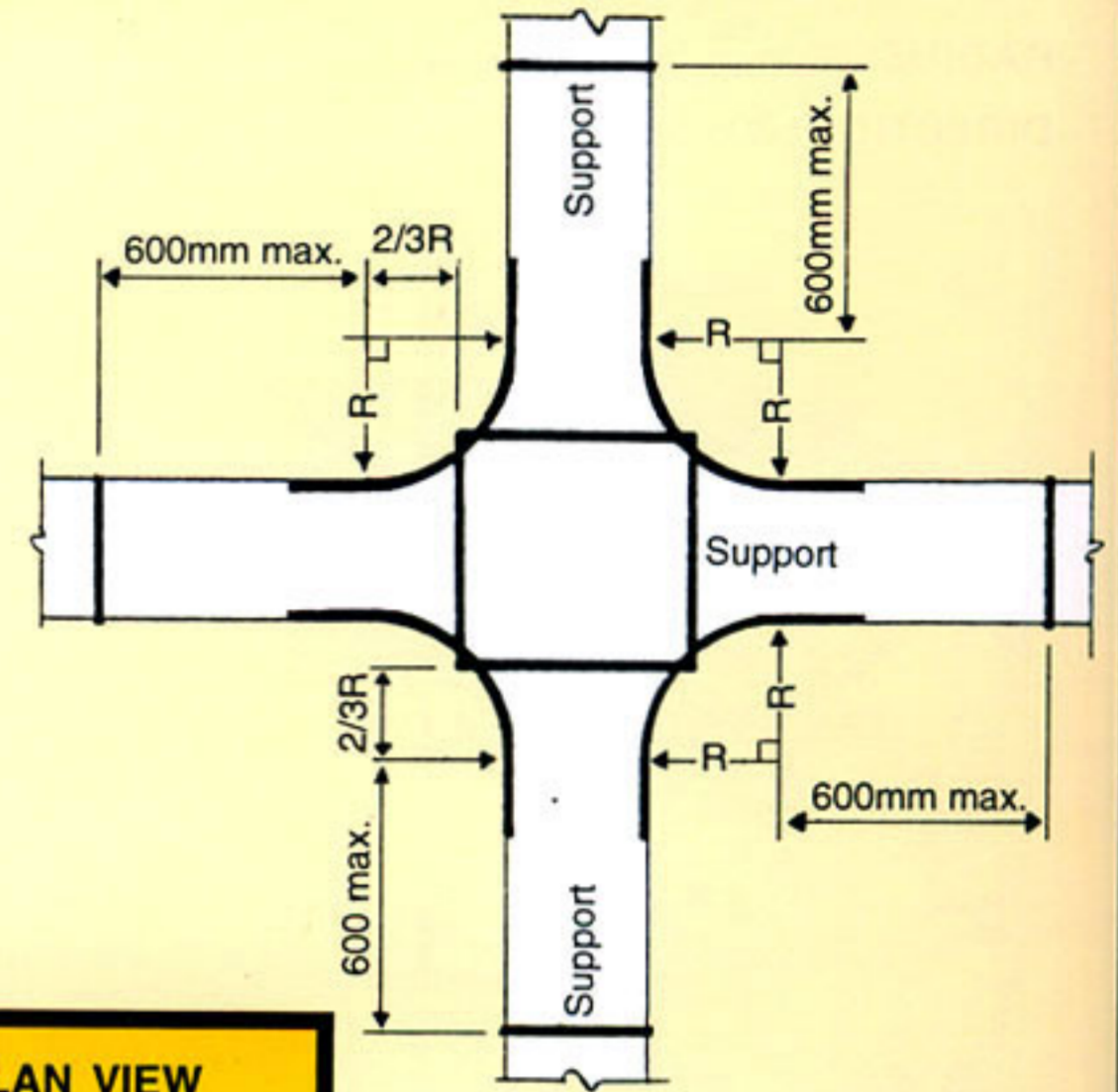

PLAN VIEW

HORIZONTAL EQUAL CROSS IN HOT DIP GALVANISED FINISH

ORDERING PART NUMBERS

TYPES	BES-12 Series	BES-16 Series	BES-20 Series	DIRECTION	WIDTH
PART NUMBERS	SHX-12-15W-300R	SHX-16-15W-300R	SHX-20-15W-300R	90°	150mm
	SHX-12-30W-300R	SHX-16-30W-300R	SHX-20-30W-300R		300mm
	SHX-12-45W-300R	SHX-16-45W-300R	SHX-20-45W-300R		450mm
	SHX-12-60W-300R	SHX-16-60W-300R	SHX-20-60W-300R		600mm
	SHX-12-76W-300R	SHX-16-76W-300R	SHX-20-76W-300R		760mm
	SHX-12-90W-300R	SHX-16-90W-300R	SHX-20-90W-300R		900mm

HORIZONTAL EQUAL CROSS IN ALUMINIUM MILL FINISH

PART NUMBERS	AHX-12-15W-300R	AHX-16-15W-300R	AHX-20-15W-300R	90°	150mm
	AHX-12-30W-300R	AHX-16-30W-300R	AHX-20-30W-300R		300mm
	AHX-12-45W-300R	AHX-16-45W-300R	AHX-20-45W-300R		450mm
	AHX-12-60W-300R	AHX-16-60W-300R	AHX-20-60W-300R		600mm
	AHX-12-76W-300R	AHX-16-76W-300R	AHX-20-76W-300R		760mm
	AHX-12-90W-300R	AHX-16-90W-300R	AHX-20-90W-300R		900mm

HORIZONTAL EQUAL CROSS IN STAINLESS STEEL 2B FINISH

PART NUMBERS (specify grade i.e. AISI 304 OR AISI 316L)	SSHX-12-15W-300R	SSHX-16-15W-300R	SSHX-20-15W-300R	90°	150mm
	SSHX-12-30W-300R	SSHX-16-30W-300R	SSHX-20-30W-300R		300mm
	SSHX-12-45W-300R	SSHX-16-45W-300R	SSHX-20-45W-300R		450mm
	SSHX-12-60W-300R	SSHX-16-60W-300R	SSHX-20-60W-300R		600mm
	SSHX-12-76W-300R	SSHX-16-76W-300R	SSHX-20-76W-300R		760mm
	SSHX-12-90W-300R	SSHX-16-90W-300R	SSHX-20-90W-300R		900mm

CABLE LADDER ACCESSORIES...

HORIZONTAL EQUAL TEE

RADIUS: 300mm (450mm & 600mm on request)

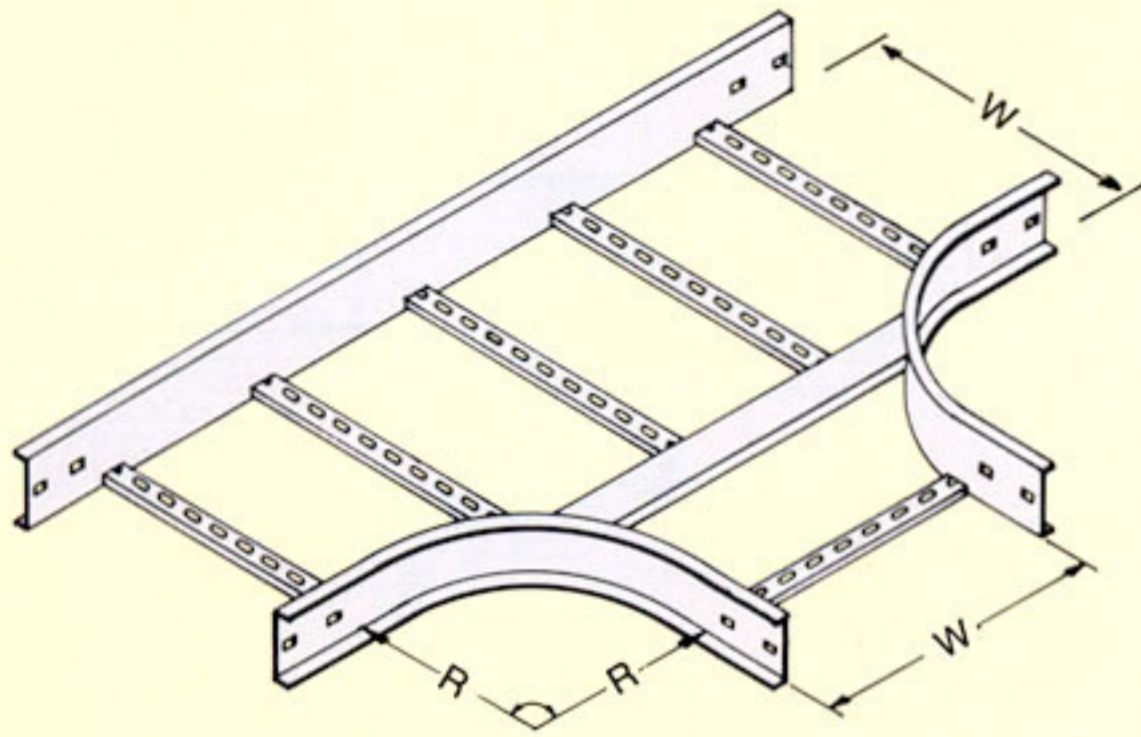

PICTURAL VIEW

SUPPORTS LOCATION RECOMMENDED BY NEMA

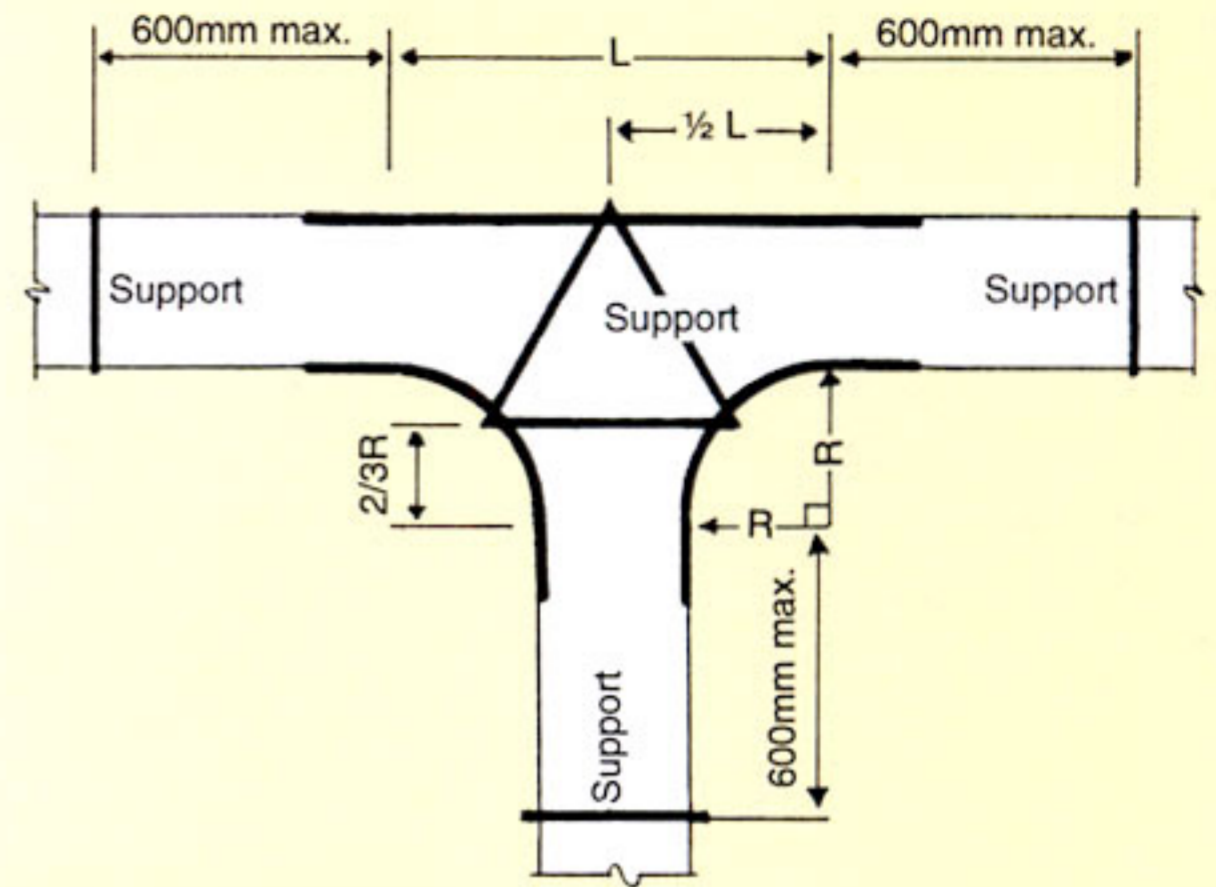

PLAN VIEW

HORIZONTAL EQUAL TEE IN HOT DIP GALVANISED FINISH

ORDERING PART NUMBERS

TYPES	BES-12 Series	BES-16 Series	BES-20 Series	DIRECTION	WIDTH
PART NUMBERS	SET-12-15W-300R	SET-16-15W-300R	SET-20-15W-300R	90°	150mm
	SET-12-30W-300R	SET-16-30W-300R	SET-20-30W-300R		300mm
	SET-12-45W-300R	SET-16-45W-300R	SET-20-45W-300R		450mm
	SET-12-60W-300R	SET-16-60W-300R	SET-20-60W-300R		600mm
	SET-12-76W-300R	SET-16-76W-300R	SET-20-76W-300R		760mm
	SET-12-90W-300R	SET-16-90W-300R	SET-20-90W-300R		900mm

HORIZONTAL EQUAL TEE IN ALUMINIUM MILL FINISH

PART NUMBERS	AET-12-15W-300R	AET-16-15W-300R	AET-20-15W-300R	90°	150mm
	AET-12-30W-300R	AET-16-30W-300R	AET-20-30W-300R		300mm
	AET-12-45W-300R	AET-16-45W-300R	AET-20-45W-300R		450mm
	AET-12-60W-300R	AET-16-60W-300R	AET-20-60W-300R		600mm
	AET-12-76W-300R	AET-16-76W-300R	AET-20-76W-300R		760mm
	AET-12-90W-300R	AET-16-90W-300R	AET-20-90W-300R		900mm

HORIZONTAL EQUAL TEE IN STAINLESS STEEL 2B FINISH

PART NUMBERS (specify grade i.e. AISI 304 OR AISI 316L)	SSET-12-15W-300R	SSET-16-15W-300R	SSET-20-15W-300R	90°	150mm
	SSET-12-30W-300R	SSET-16-30W-300R	SSET-20-30W-300R		300mm
	SSET-12-45W-300R	SSET-16-45W-300R	SSET-20-45W-300R		450mm
	SSET-12-60W-300R	SSET-16-60W-300R	SSET-20-60W-300R		600mm
	SSET-12-76W-300R	SSET-16-76W-300R	SSET-20-76W-300R		760mm
	SSET-12-90W-300R	SSET-16-90W-300R	SSET-20-90W-300R		900mm

CABLE LADDER ACCESSORIES...

HORIZONTAL UNEQUAL TEE

RADIUS: 300mm (450mm & 600mm on request)

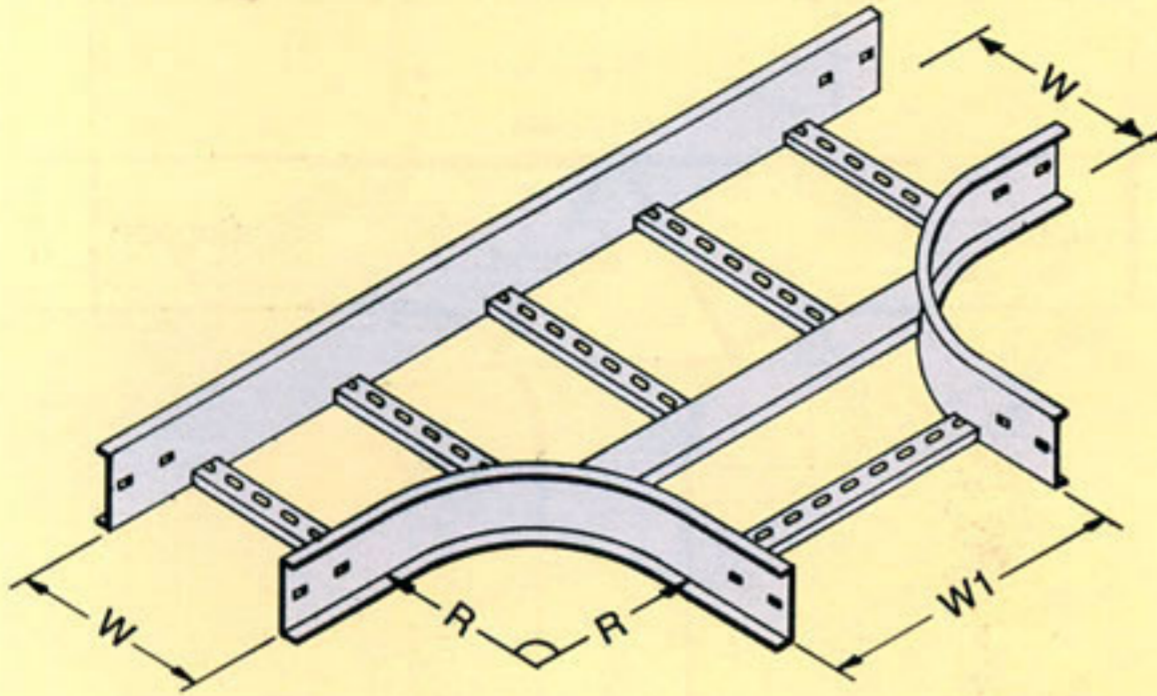

PICTORIAL VIEW

SUPPORTS LOCATION RECOMMENDED BY NEMA.

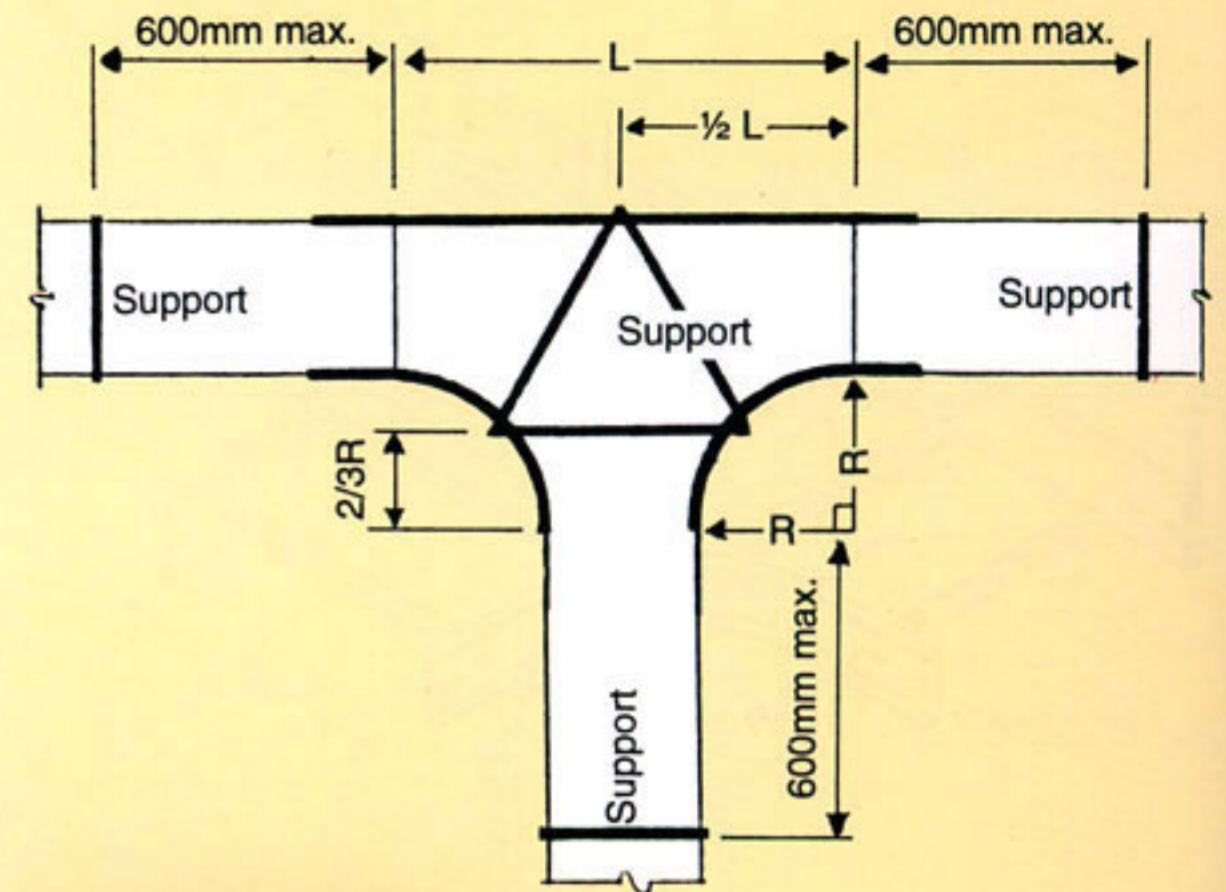

PLAN VIEW

HORIZONTAL UNEQUAL TEE IN HOT DIP GALVANISED FINISH

ORDERING PART NUMBERS

TYPES	BES-12 Series	BES-16 Series	BES-20 Series	W	W1
PART NUMBERS	SUT-12-1530W-300R	SUT-16-1530W-300R	SUT-20-1530W-300R	150	300
	SUT-12-1545W-300R	SUT-16-1545W-300R	SUT-20-1545W-300R	150	450
	SUT-12-1560W-300R	SUT-16-1560W-300R	SUT-20-1560W-300R	150	600
	SUT-12-1576W-300R	SUT-16-1576W-300R	SUT-20-1576W-300R	150	760
	SUT-12-1590W-300R	SUT-16-1590W-300R	SUT-20-1590W-300R	150	900
Use of Prefix	SUT-12-3015W-300R	SUT-16-3015W-300R	SUT-20-3015W-300R	300	150
	SUT-12-3045W-300R	SUT-16-3045W-300R	SUT-20-3045W-300R	300	450
	SUT-12-3060W-300R	SUT-16-3060W-300R	SUT-20-3060W-300R	300	600
	SUT-12-3076W-300R	SUT-16-3076W-300R	SUT-20-3076W-300R	300	760
	SUT-12-3090W-300R	SUT-16-3090W-300R	SUT-20-3090W-300R	300	900
a) FOR ALUM FINISH	SUT-12-4515W-300R	SUT-16-4515W-300R	SUT-20-4515W-300R	450	150
	SUT-12-4530W-300R	SUT-16-4530W-300R	SUT-20-4530W-300R	450	300
	SUT-12-4560W-300R	SUT-16-4560W-300R	SUT-20-4560W-300R	450	600
	SUT-12-4576W-300R	SUT-16-4576W-300R	SUT-20-4576W-300R	450	760
	SUT-12-4590W-300R	SUT-16-4590W-300R	SUT-20-4590W-300R	450	900
use AUT 12 - or AUT 16 - AUT 20 -	SUT-12-6015W-300R	SUT-16-6015W-300R	SUT-20-6015W-300R	600	150
	SUT-12-6030W-300R	SUT-16-6030W-300R	SUT-20-6030W-300R	600	300
	SUT-12-6045W-300R	SUT-16-6045W-300R	SUT-20-6045W-300R	600	450
	SUT-12-6076W-300R	SUT-16-6076W-300R	SUT-20-6076W-300R	600	760
	SUT-12-6090W-300R	SUT-16-6090W-300R	SUT-20-6090W-300R	600	900
b) FOR STAINLESS STEEL FINISH	SUT-12-7615W-300R	SUT-16-7615W-300R	SUT-20-7615W-300R	760	150
	SUT-12-7630W-300R	SUT-16-7630W-300R	SUT-20-7630W-300R	760	300
	SUT-12-7645W-300R	SUT-16-7645W-300R	SUT-20-7645W-300R	760	450
	SUT-12-7660W-300R	SUT-16-7660W-300R	SUT-20-7660W-300R	760	600
	SUT-12-7690W-300R	SUT-16-7690W-300R	SUT-20-7690W-300R	760	900
use SSUT 12 - or SSUT 16 - SSUT 20 - and specify grade.	SUT-12-9015W-300R	SUT-16-9015W-300R	SUT-20-9015W-300R	900	150
	SUT-12-9030W-300R	SUT-16-9030W-300R	SUT-20-9030W-300R	900	300
	SUT-12-9045W-300R	SUT-16-9045W-300R	SUT-20-9045W-300R	900	450
	SUT-12-9060W-300R	SUT-16-9060W-300R	SUT-20-9060W-300R	900	600
	SUT-12-9076W-300R	SUT-16-9076W-300R	SUT-20-9076W-300R	900	760

CABLE LADDER ACCESSORIES...

INTERNAL VERTICAL ELBOW

RADIUS: 450mm (300mm & 600mm on request)
DIRECTION: 30°, 45°, 60°, 90°

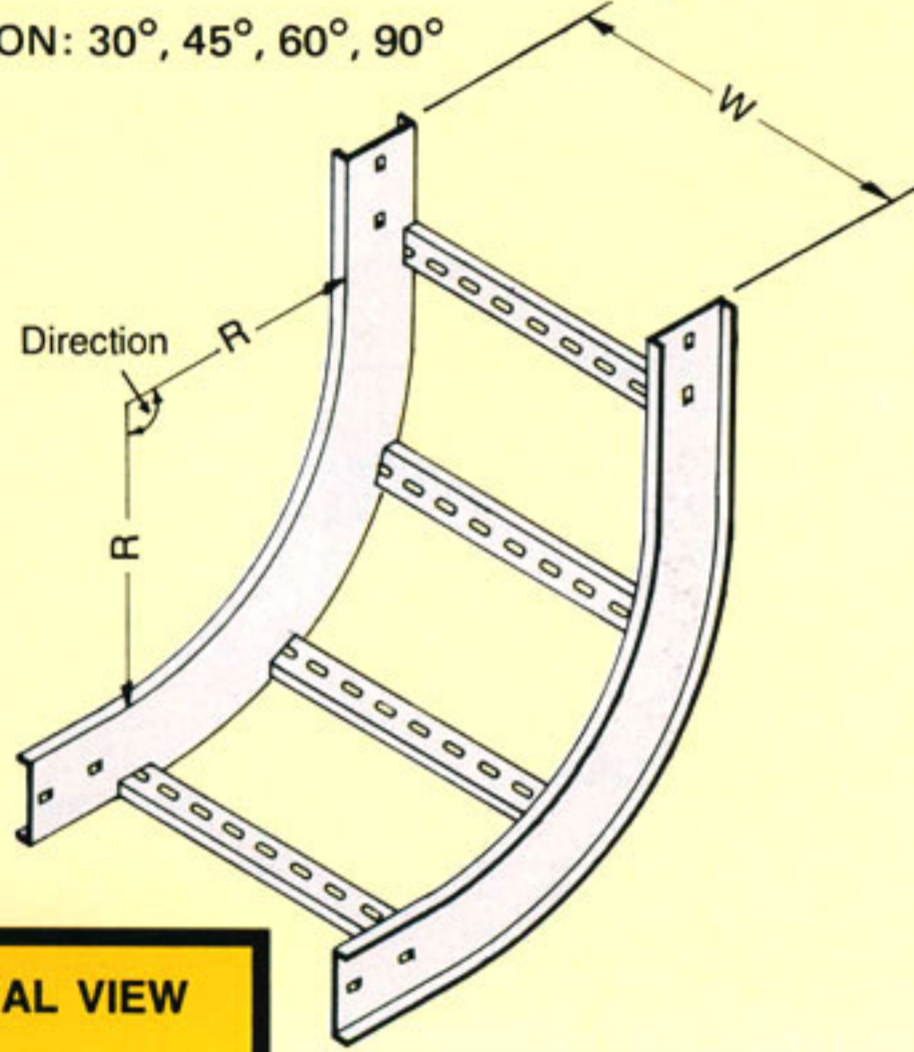

PICTURAL VIEW

SUPPORTS LOCATION RECOMMENDED BY NEMA.

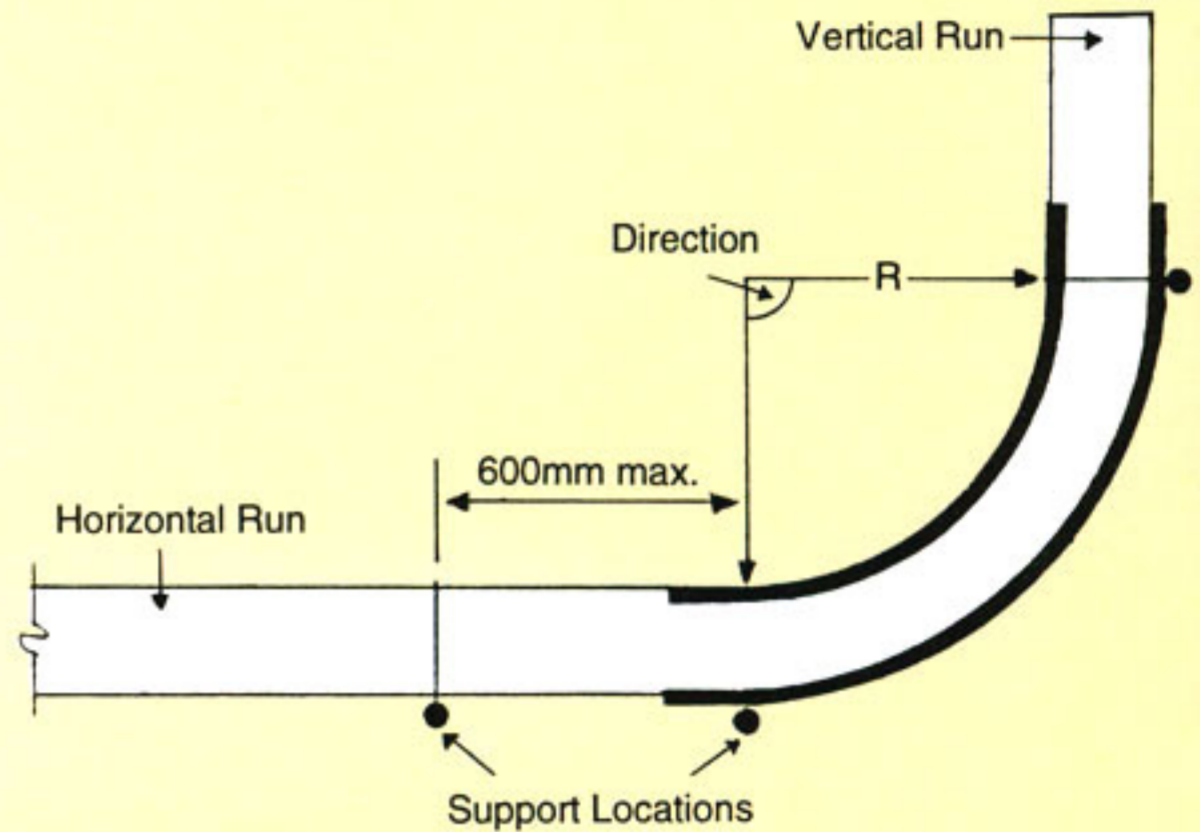

ELEVATIONAL VIEW

INTERNAL VERTICAL ELBOW IN HOT DIP GALVANISED FINISH

ORDERING PART NUMBERS

TYPES	BES-12 Series	BES-16 Series	BES-20 Series	DIRECTION	WIDTH
PART NUMBERS	SIVE-12-15W-450R	SIVE-16-15W-450R	SIVE-20-15W-450R	Usually 90° (30°, 45° & 60° available on request)	150mm
	SIVE-12-30W-450R	SIVE-16-30W-450R	SIVE-20-30W-450R		300mm
	SIVE-12-45W-450R	SIVE-16-45W-450R	SIVE-20-45W-450R		450mm
	SIVE-12-60W-450R	SIVE-16-60W-450R	SIVE-20-60W-450R		600mm
	SIVE-12-76W-450R	SIVE-16-76W-450R	SIVE-20-76W-450R		760mm
	SIVE-12-90W-450R	SIVE-16-90W-450R	SIVE-20-90W-450R		900mm

INTERNAL VERTICAL ELBOW IN ALUMINIUM MILL FINISH

PART NUMBERS	AIVE-12-15W-450R	AIVE-16-15W-450R	AIVE-20-15W-450R	Usually 90° (30°, 45° & 60° available on request)	150mm
	AIVE-12-30W-450R	AIVE-16-30W-450R	AIVE-20-30W-450R		300mm
	AIVE-12-45W-450R	AIVE-16-45W-450R	AIVE-20-45W-450R		450mm
	AIVE-12-60W-450R	AIVE-16-60W-450R	AIVE-20-60W-450R		600mm
	AIVE-12-76W-450R	AIVE-16-76W-450R	AIVE-20-76W-450R		760mm
	AIVE-12-90W-450R	AIVE-16-90W-450R	AIVE-20-90W-450R		900mm

INTERNAL VERTICAL ELBOW IN STAINLESS STEEL 2B FINISH

PART NUMBERS (Specify grade i.e. AISI 304 OR AISI 316L)	SSIVE-12-15W-450R	SSIVE-16-15W-450R	SSIVE-20-15W-450R	Usually 90° (30°, 45° & 60° available on request)	150mm
	SSIVE-12-30W-450R	SSIVE-16-30W-450R	SSIVE-20-30W-450R		300mm
	SSIVE-12-45W-450R	SSIVE-16-45W-450R	SSIVE-20-45W-450R		450mm
	SSIVE-12-60W-450R	SSIVE-16-60W-450R	SSIVE-20-60W-450R		600mm
	SSIVE-12-76W-450R	SSIVE-16-76W-450R	SSIVE-20-76W-450R		760mm
	SSIVE-12-90W-450R	SSIVE-16-90W-450R	SSIVE-20-90W-450R		900mm

CABLE LADDER ACCESSORIES...

EXTERNAL VERTICAL ELBOW

RADIUS: 450mm (300mm & 600mm on request)
DIRECTION: 30°, 45°, 60°, 90°

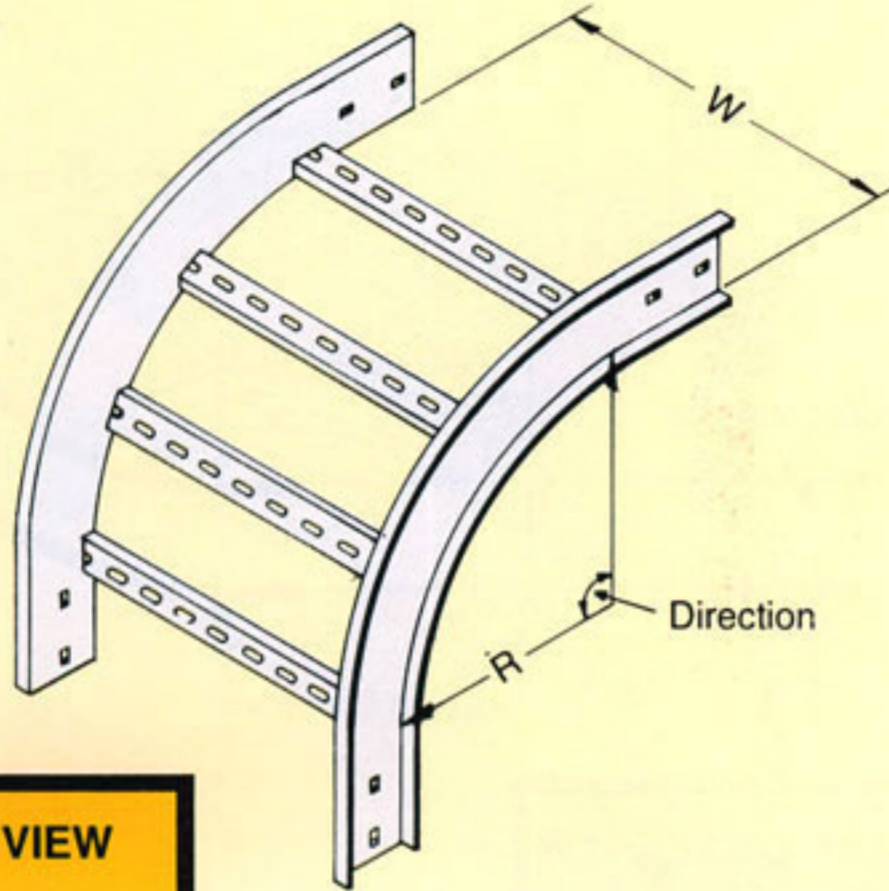

PICTURAL VIEW

SUPPORTS LOCATION RECOMMENDED BY NEMA.

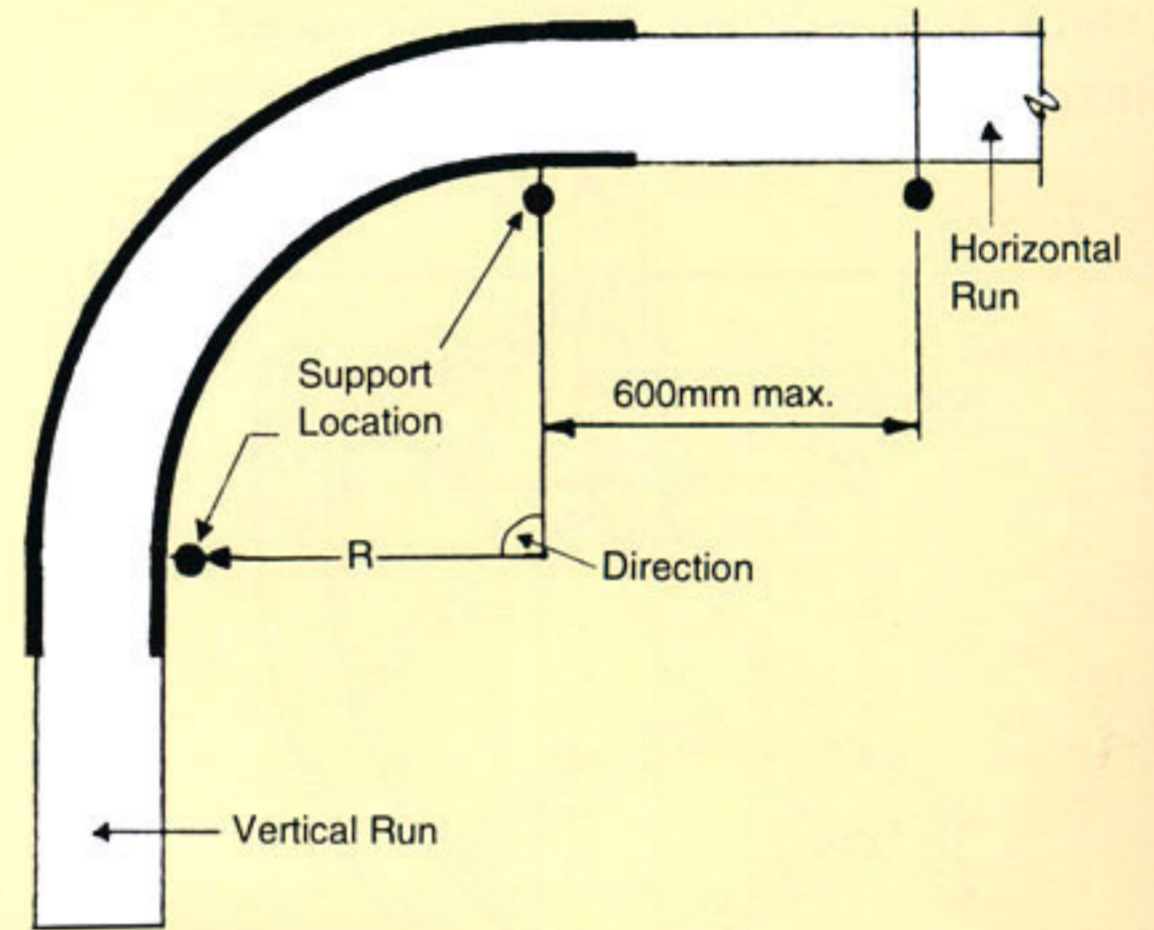

ELEVATIONAL VIEW

EXTERNAL VERTICAL ELBOW IN HOT DIP GALVANISED FINISH

ORDERING PART NUMBERS

TYPES	BES-12 Series	BES-16 Series	BES-20 Series	DIRECTION	WIDTH
PART NUMBERS	SEVE-12-15W-450R	SEVE-16-15W-450R	SEVE-20-15W-450R	Usually 90° (30°, 45° & 60° available on request)	150mm
	SEVE-12-30W-450R	SEVE-16-30W-450R	SEVE-20-30W-450R		300mm
	SEVE-12-45W-450R	SEVE-16-45W-450R	SEVE-20-45W-450R		450mm
	SEVE-12-60W-450R	SEVE-16-60W-450R	SEVE-20-60W-450R		600mm
	SEVE-12-76W-450R	SEVE-16-76W-450R	SEVE-20-76W-450R		760mm
	SEVE-12-90W-450R	SEVE-16-90W-450R	SEVE-20-90W-450R		900mm

EXTERNAL VERTICAL ELBOW IN ALUMINIUM MILL FINISH

PART NUMBERS	AEVE-12-15W-450R	AEVE-16-15W-450R	AEVE-20-15W-450R	Usually 90° (30°, 45° & 60° available on request)	150mm
	AEVE-12-30W-450R	AEVE-16-30W-450R	AEVE-20-30W-450R		300mm
	AEVE-12-45W-450R	AEVE-16-45W-450R	AEVE-20-45W-450R		450mm
	AEVE-12-60W-450R	AEVE-16-60W-450R	AEVE-20-60W-450R		600mm
	AEVE-12-76W-450R	AEVE-16-76W-450R	AEVE-20-76W-450R		760mm
	AEVE-12-90W-450R	AEVE-16-90W-450R	AEVE-20-90W-450R		900mm

EXTERNAL VERTICAL ELBOW IN STAINLESS STEEL 2B FINISH

PART NUMBERS (Specify grade i.e. AISI 304 OR AISI 316L)	SSEVE-12-15W-450R	SSEVE-16-15W-450R	SSEVE-20-15W-450R	Usually 90° (30°, 45° & 60° available on request)	150mm
	SSEVE-12-30W-450R	SSEVE-16-30W-450R	SSEVE-20-30W-450R		300mm
	SSEVE-12-45W-450R	SSEVE-16-45W-450R	SSEVE-20-45W-450R		450mm
	SSEVE-12-60W-450R	SSEVE-16-60W-450R	SSEVE-20-60W-450R		600mm
	SSEVE-12-76W-450R	SSEVE-16-76W-450R	SSEVE-20-76W-450R		760mm
	SSEVE-12-90W-450R	SSEVE-16-90W-450R	SSEVE-20-90W-450R		900mm

CABLE LADDER ACCESSORIES...

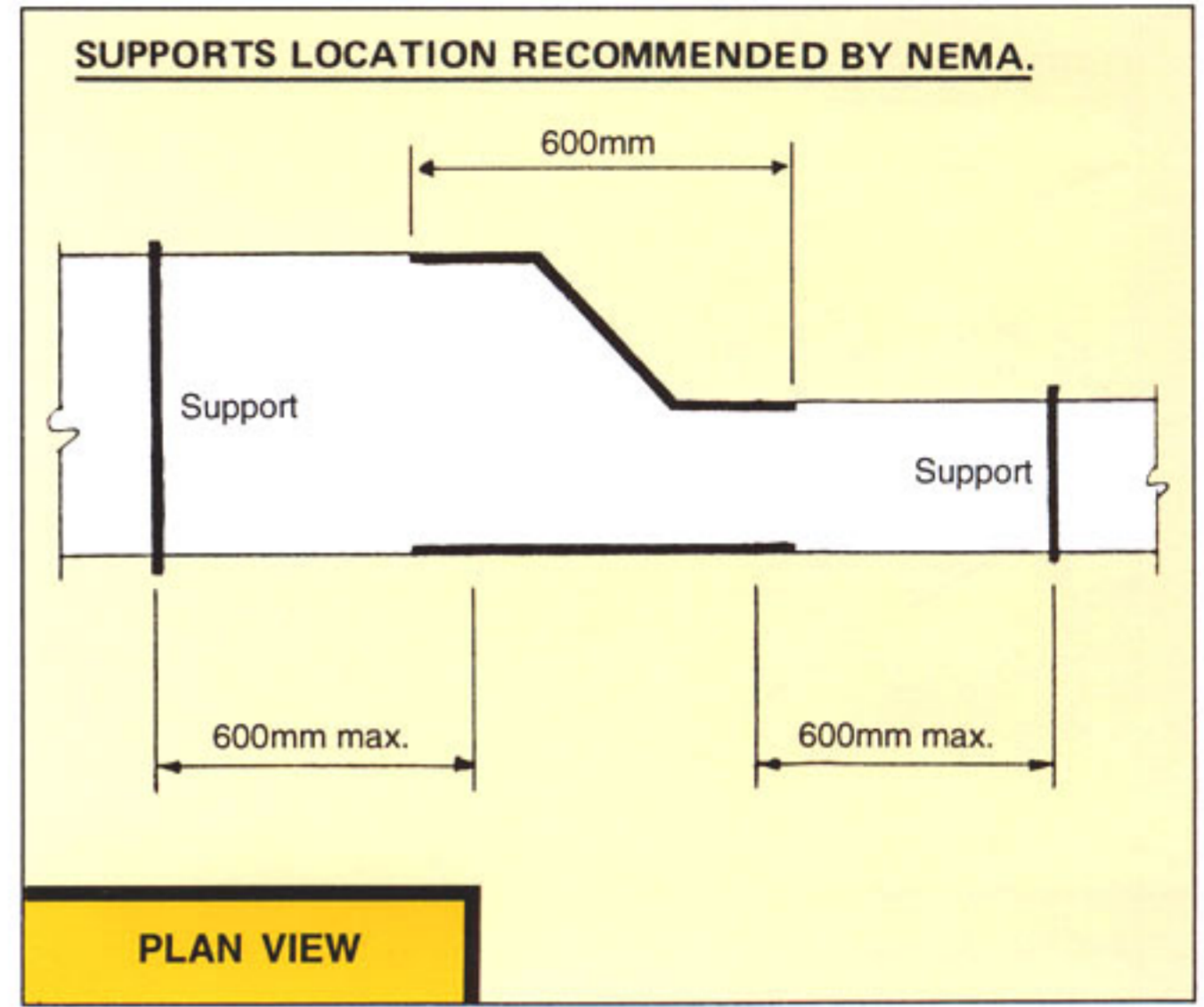
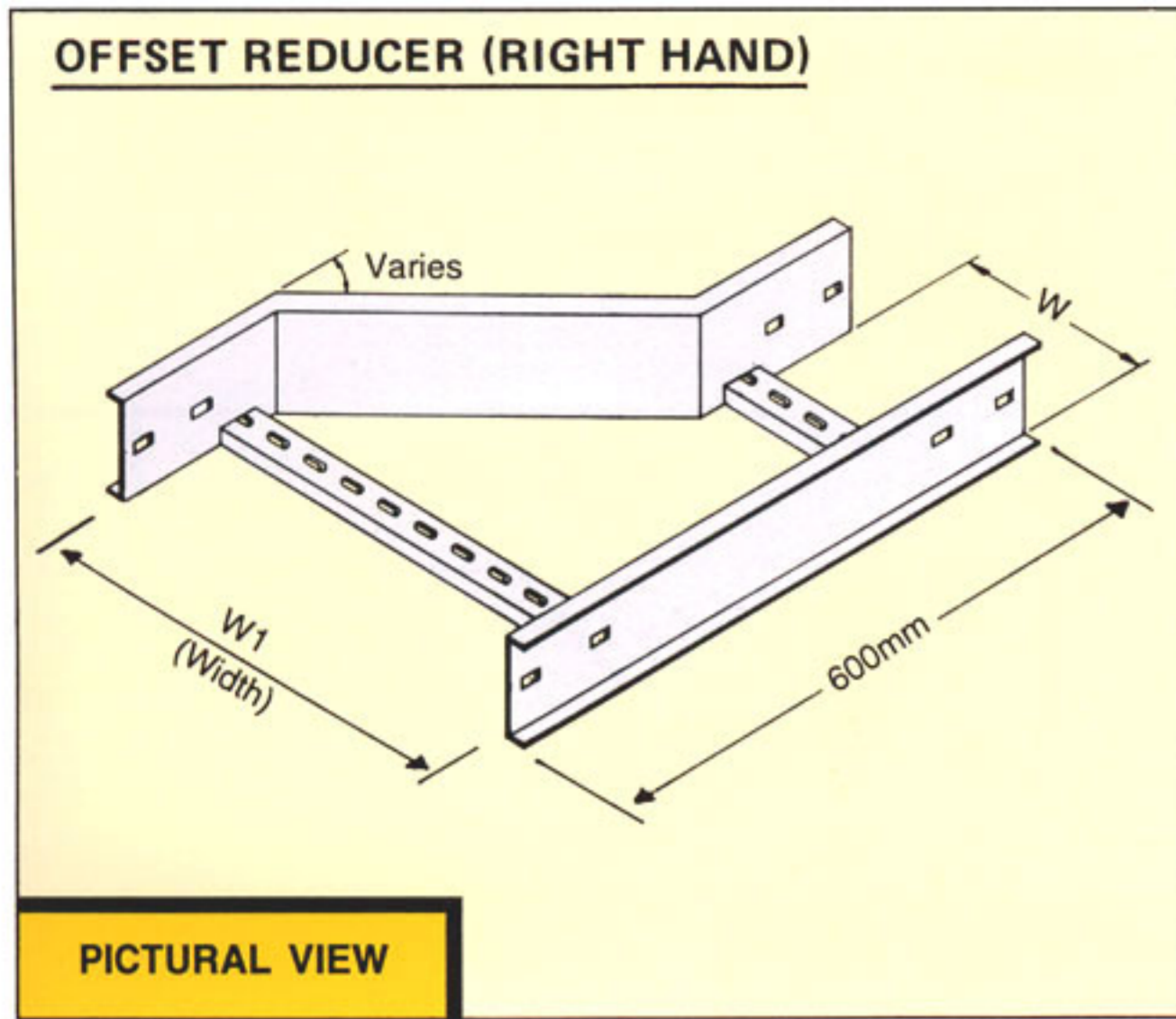

OFFSET REDUCER (RIGHT HAND) IN HOT DIP GALVANISED FINISH

ORDERING PART NUMBERS

TYPE	BES-12 Series	BES-16 Series	BES-20 Series	W	W1
PART NUMBERS	SOR-12 - 1530WR	SOR-16 - 1530WR	SOR-20 - 1530WR	150mm	300mm
	SOR-12 - 1545WR	SOR-16 - 1545WR	SOR-20 - 1545WR	150mm	450mm
	SOR-12 - 1560WR	SOR-16 - 1560WR	SOR-20 - 1560WR	150mm	600mm
	SOR-12 - 1576WR	SOR-16 - 1576WR	SOR-20 - 1576WR	150mm	760mm
	SOR-12 - 1590WR	SOR-16 - 1590WR	SOR-20 - 1590WR	150mm	900mm
	SOR-12 - 3045WR	SOR-16 - 3045WR	SOR-20 - 3045WR	300mm	450mm
	SOR-12 - 3060WR	SOR-16 - 3060WR	SOR-20 - 3060WR	300mm	600mm
	SOR-12 - 3076WR	SOR-16 - 3076WR	SOR-20 - 3076WR	300mm	760mm
	SOR-12 - 3090WR	SOR-16 - 3090WR	SOR-20 - 3090WR	300mm	900mm
	SOR-12 - 4560WR	SOR-16 - 4560WR	SOR-20 - 4560WR	450mm	600mm
	SOR-12 - 4576WR	SOR-16 - 4576WR	SOR-20 - 4576WR	450mm	760mm
	SOR-12 - 4590WR	SOR-16 - 4590WR	SOR-20 - 4590WR	450mm	900mm
	SOR-12 - 6076WR	SOR-16 - 6076WR	SOR-20 - 6076WR	600mm	760mm
	SOR-12 - 6090WR	SOR-16 - 6090WR	SOR-20 - 6090WR	600mm	900mm
	SOR-12 - 7690WR	SOR-16 - 7690WR	SOR-20 - 7690WR	760mm	900mm

Offset Reducer (Right Hand) in Aluminium Mill Finish

Use prefix **AOR-12**, **AOR-16** or **AOR-20**

Example: **AOR-12** - 1530WR for BES-12 Series,
AOR-16 - 1530WR for BES-16 Series
AOR-20 - 1530WR for BES-20 Series.

Offset Reducer (Right Hand) in Stainless Steel 2B finish.

Use prefix **SSOR-12**, **SSOR-16**, or **SSOR-20** and specify grade.

Example: **SSOR-12** - 1530WR 304] for BES-12 Series
SSOR-12 - 1530WR 316L] for BES-12 Series
SSOR-16 - 1530WR 304] for BES-16 Series
SSOR-16 - 1530WR 316L] for BES-16 Series
SSOR-20 - 1530WR 304] for BES-20 Series
SSOR-20 - 1530WR 316L] for BES-20 Series

**USE OF
PART
NUMBERS**

CABLE LADDER ACCESSORIES...

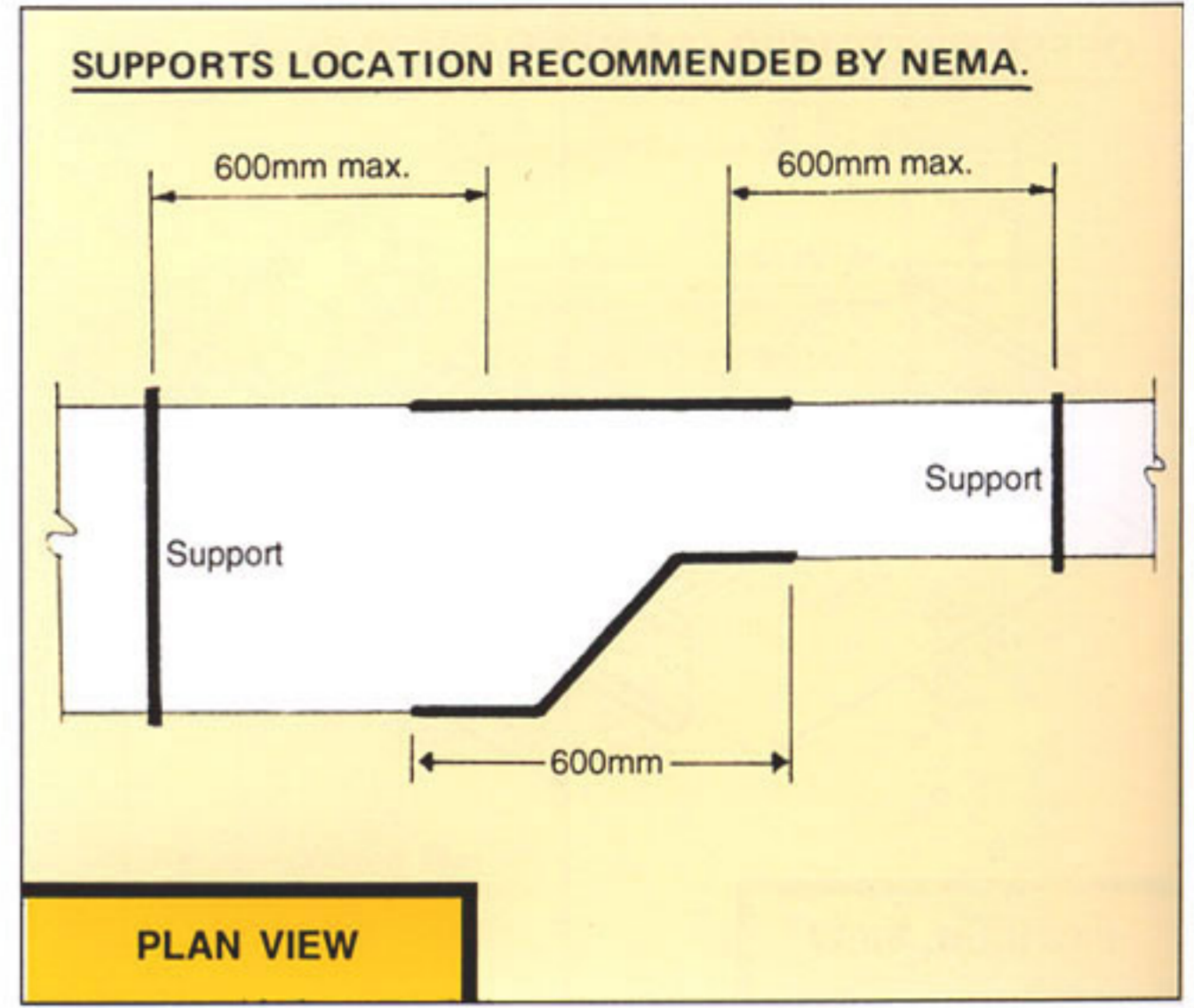
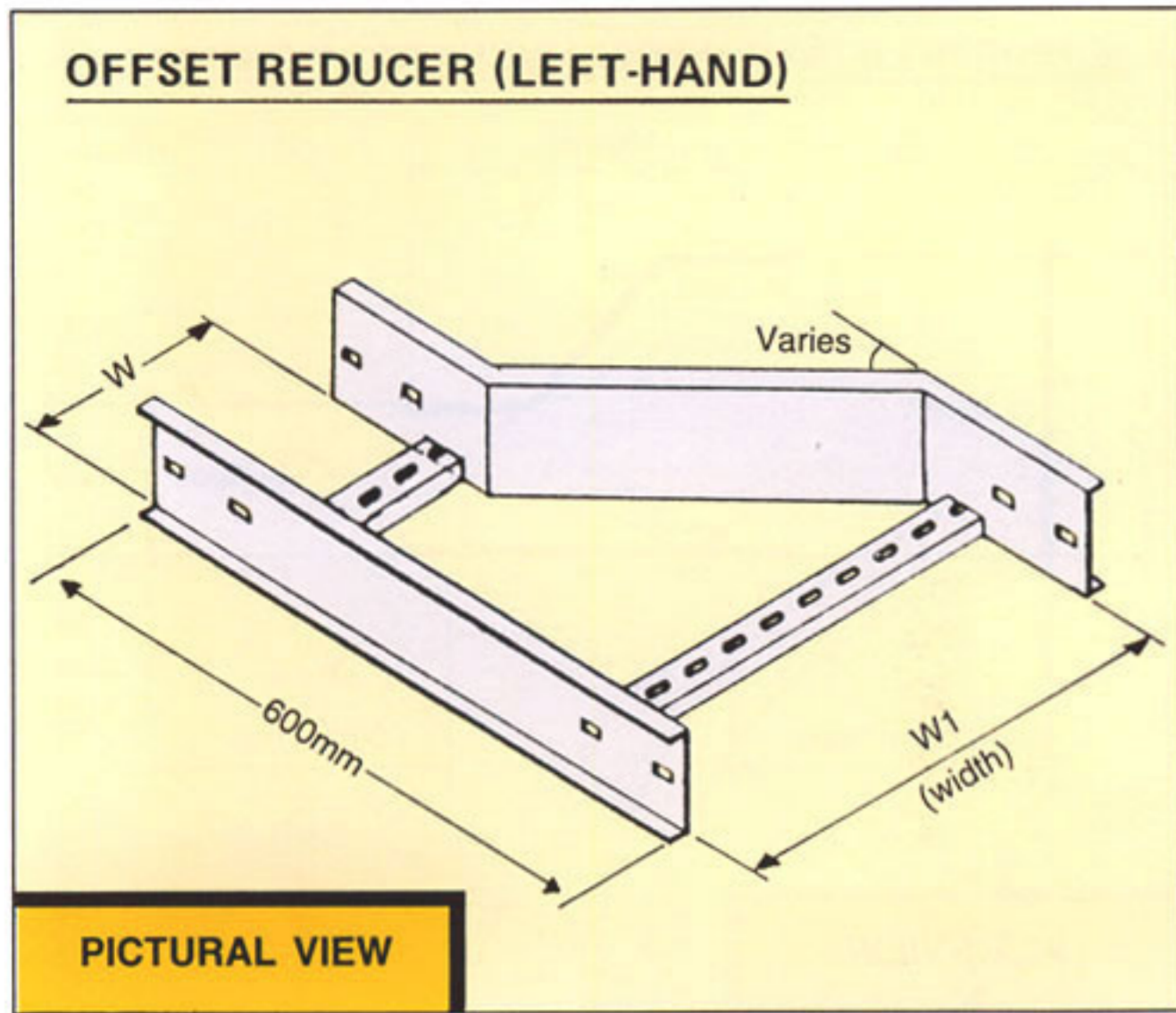

OFFSET REDUCER (LEFT HAND) IN HOT DIP GALVANISED FINISH

ORDERING PART NUMBERS

TYPE	BES-12 Series	BES-16 Series	BES-20 Series	W	W1
PART NUMBERS	SOR-12 - 1530WL	SOR-16 - 1530WL	SOR-20 - 1530WL	150mm	300mm
	SOR-12 - 1545WL	SOR-16 - 1545WL	SOR-20 - 1545WL	150mm	450mm
	SOR-12 - 1560WL	SOR-16 - 1560WL	SOR-20 - 1560WL	150mm	600mm
	SOR-12 - 1576WL	SOR-16 - 1576WL	SOR-20 - 1576WL	150mm	760mm
	SOR-12 - 1590WL	SOR-16 - 1590WL	SOR-20 - 1590WL	150mm	900mm
	SOR-12 - 3045WL	SOR-16 - 3045WL	SOR-20 - 3045WL	300mm	450mm
	SOR-12 - 3060WL	SOR-16 - 3060WL	SOR-20 - 3060WL	300mm	600mm
	SOR-12 - 3076WL	SOR-16 - 3076WL	SOR-20 - 3076WL	300mm	760mm
	SOR-12 - 3090WL	SOR-16 - 3090WL	SOR-20 - 3090WL	300mm	900mm
	SOR-12 - 4560WL	SOR-16 - 4560WL	SOR-20 - 4560WL	450mm	600mm
	SOR-12 - 4576WL	SOR-16 - 4576WL	SOR-20 - 4576WL	450mm	760mm
	SOR-12 - 4590WL	SOR-16 - 4590WL	SOR-20 - 4590WL	450mm	900mm
	SOR-12 - 6076WL	SOR-16 - 6076WL	SOR-20 - 6076WL	600mm	760mm
	SOR-12 - 6090WL	SOR-16 - 6090WL	SOR-20 - 6090WL	600mm	900mm
	SOR-12 - 7690WL	SOR-16 - 7690WL	SOR-20 - 7690WL	760mm	900mm

USE OF
PART
NUMBERS

Offset Reducer (Left Hand) in Aluminium Mill Finish
Use prefix **AOR-12**, **AOR-16** or **AOR-20**

Example: **AOR-12** - 1530WL for BES-12 Series
AOR-16 - 1530WL for BES-16 Series
AOR-20 - 1530WL for BES-20 Series.

Offset Reducer (Left Hand) in Stainless Steel 2B finish.
Use prefix **SSOR-12**, **SSOR-16** or **AOR-20** and specify grade.

Example: **SSOR-12** - 1530WL 304
SSOR-12 - 1530WL 316L] for BES-12 Series
SSOR-16 - 1530WL 304
SSOR-16 - 1530WL 316L] for BES-16 Series
SSOR-20 - 1530WL 304
SSOR-20 - 1530WL 316L] for BES-20 Series

CABLE LADDER ACCESSORIES...

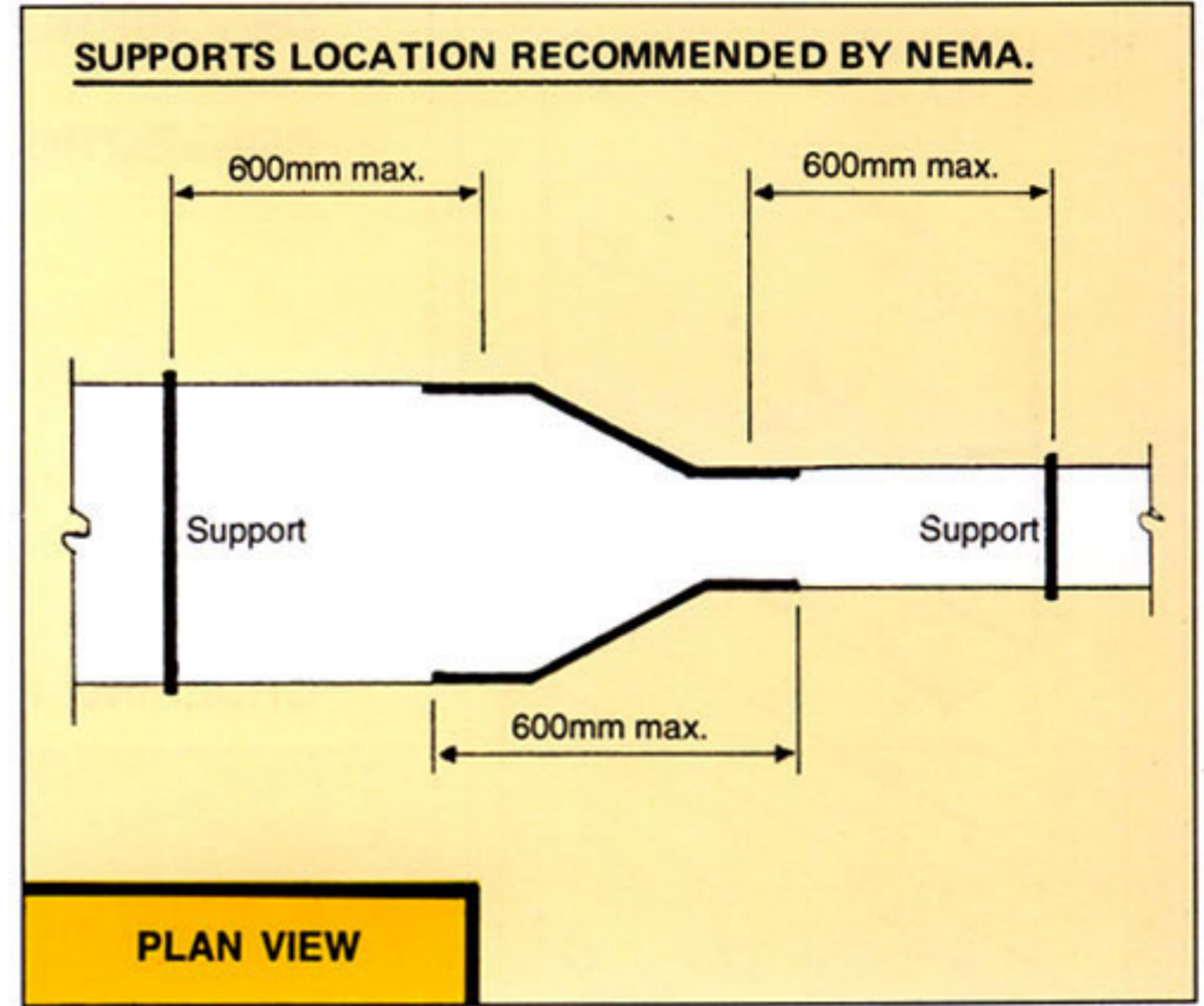
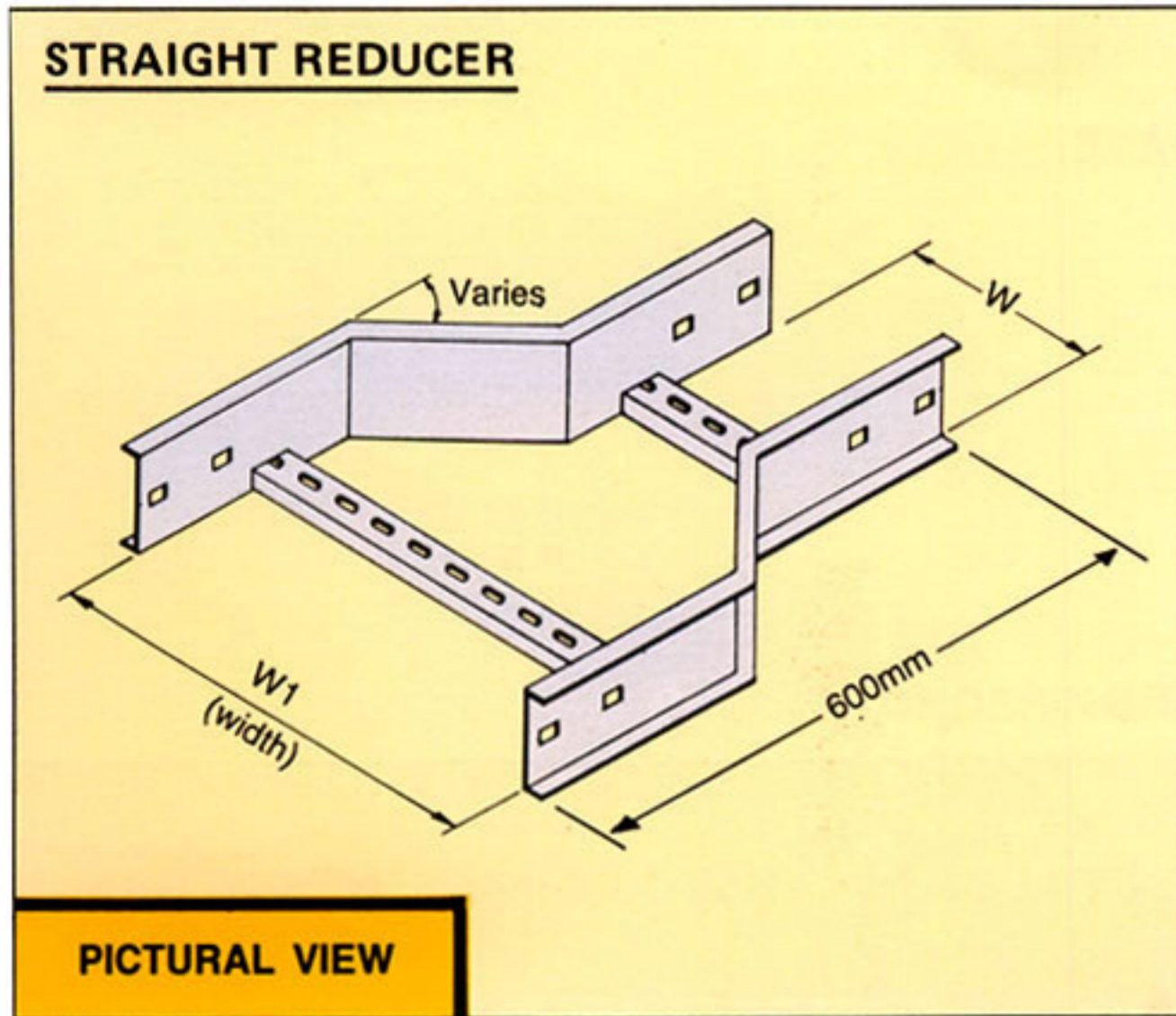

STRAIGHT REDUCER IN HOT DIP GALVANISED FINISH
ORDERING PART NUMBERS

TYPE	BES-12 Series	BES-16 Series	BES-20 Series	W	W1
Part No. NUMBERS	SR-12 - 1530W	SR-16 - 1530W	SR-20 - 1530W	150mm	300mm
	SR-12 - 1545W	SR-16 - 1545W	SR-20 - 1545W	150mm	450mm
	SR-12 - 1560W	SR-16 - 1560W	SR-20 - 1560W	150mm	600mm
	SR-12 - 1576W	SR-16 - 1576W	SR-20 - 1576W	150mm	760mm
	SR-12 - 1590W	SR-16 - 1590W	SR-20 - 1590W	150mm	900mm
	SR-12 - 3045W	SR-16 - 3045W	SR-20 - 3045W	300mm	450mm
	SR-12 - 3060W	SR-16 - 3060W	SR-20 - 3060W	300mm	600mm
	SR-12 - 3076W	SR-16 - 3076W	SR-20 - 3076W	300mm	760mm
	SR-12 - 3090W	SR-16 - 3090W	SR-20 - 3090W	300mm	900mm
	SR-12 - 4560W	SR-16 - 4560W	SR-20 - 4560W	450mm	600mm
	SR-12 - 4576W	SR-16 - 4576W	SR-20 - 4576W	450mm	760mm
	SR-12 - 4590W	SR-16 - 4590W	SR-20 - 4590W	450mm	900mm
	SR-12 - 6076W	SR-16 - 6076W	SR-20 - 6076W	600mm	760mm
	SR-12 - 6090W	SR-16 - 6090W	SR-20 - 6090W	600mm	900mm
	SR-12 - 7690W	SR-16 - 7690W	SR-20 - 7690W	760mm	900mm

Straight Reducer in Aluminium Mill Finish

Use prefix **AR-12** , **AR-16** or **AR-20**

Example: **AR-12** - 1530WL for BES-12 Series
AR-16 - 1530WL for BES-16 Series
AR-20 - 1530WL for BES-20 Series.

Offset Reducer in Stainless Steel 2B finish.

Use prefix **SSR-12** , **SSR-16** or **SSR-20** and specify grade.

Example: **SSR-12** - 1530WL 304 } for BES-12 Series
SSR-12 - 1530WL 316L }
SSR-16 - 1530WL 304 } for BES-16 Series
SSR-16 - 1530WL 316L }
SSR-20 - 1530WL 304 } for BES-20 Series
SSR-20 - 1530WL 316L }

**USE OF
PART
NUMBERS**

CABLE LADDER ACCESSORIES...

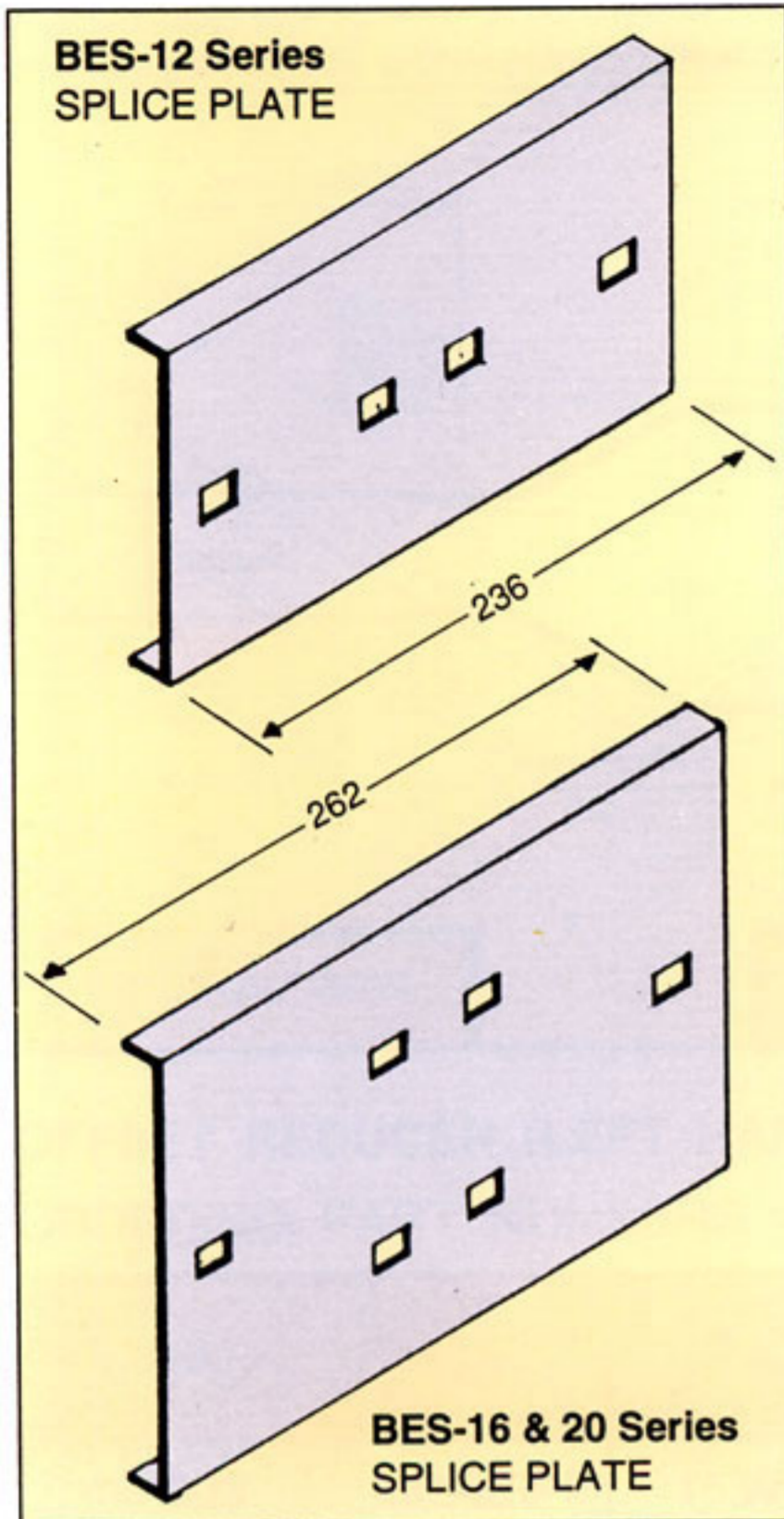

DESCRIPTION:

CONNECTION SPLICE PLATE

ORDERING PART NUMBERS

Type Materials and Part Nos.	BES-12 Series	BES-16 Series	BES-20 Series
Steel in Hot Dip Galv. finish	SCP-12	SCP-16	SCP-20
Aluminium Mill finish	ACP-12	ACP-16	ACP-20
Stainless Steel 2B finish	SSCP-12 - 304 SSCP-12 - 316L	SSCP-16 - 304 SSCP-16 - 316L	SSCP-20 - 304 SSCP-20 - 316L

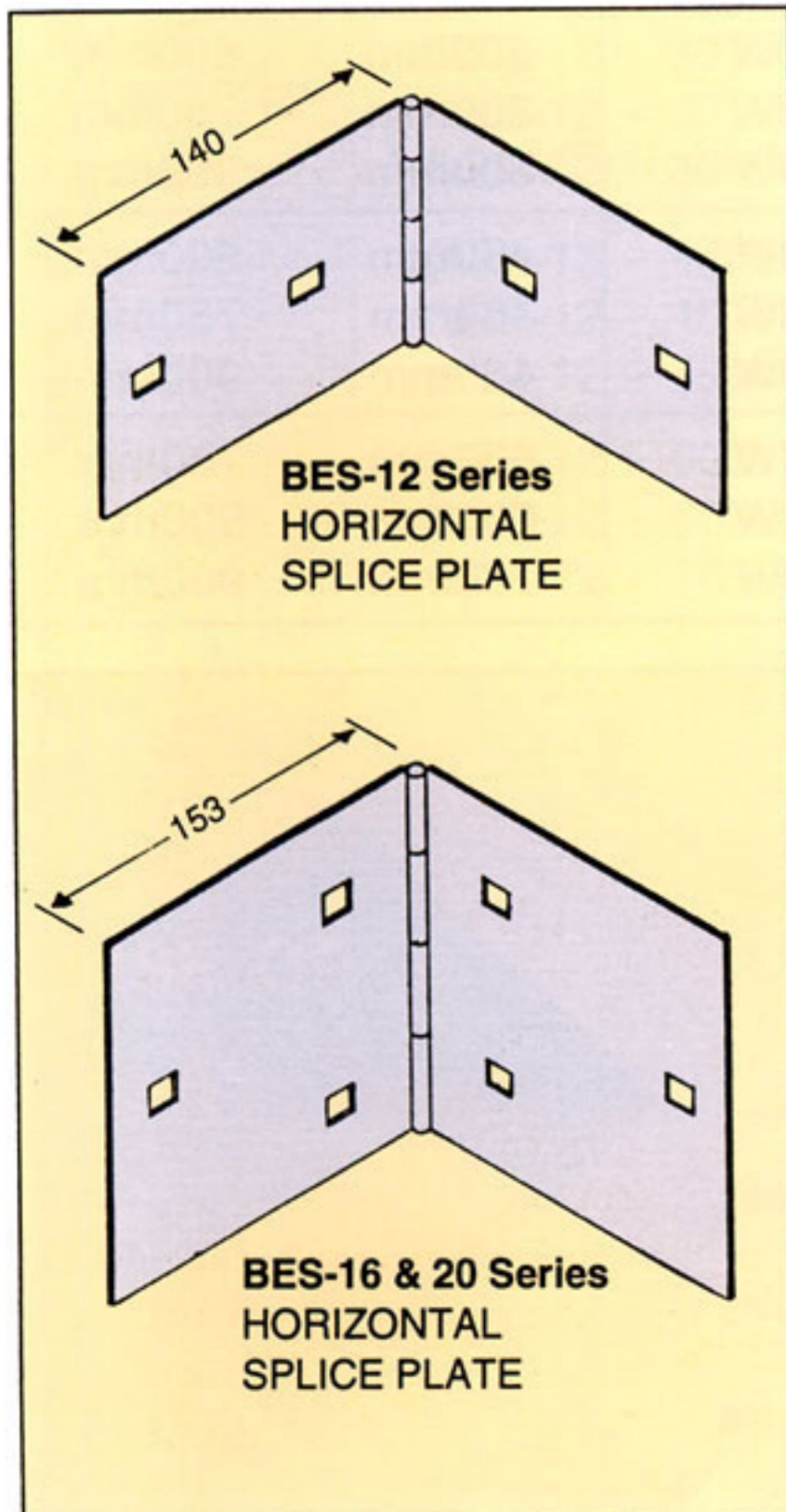

DESCRIPTION:

HORIZONTAL CONNECTION SPLICE PLATE

ORDERING PART NUMBERS

Type Materials and Part Nos.	BES-12 Series	BES-16 Series	BES-20 Series
Steel in Hot Dip Galv. finish	SHCP-12	SHCP-16	SHCP-20
Aluminium Mill finish	AHCP-12	AHCP-16	AHCP-20
Stainless Steel 2B finish	SSHCP-12 - 304 SSHCP-12 - 316L	SSHCP-16 - 304 SSHCP-16 - 316L	SSHCP-20 - 304 SSHCP-20 - 316L

CABLE LADDER ACCESSORIES...

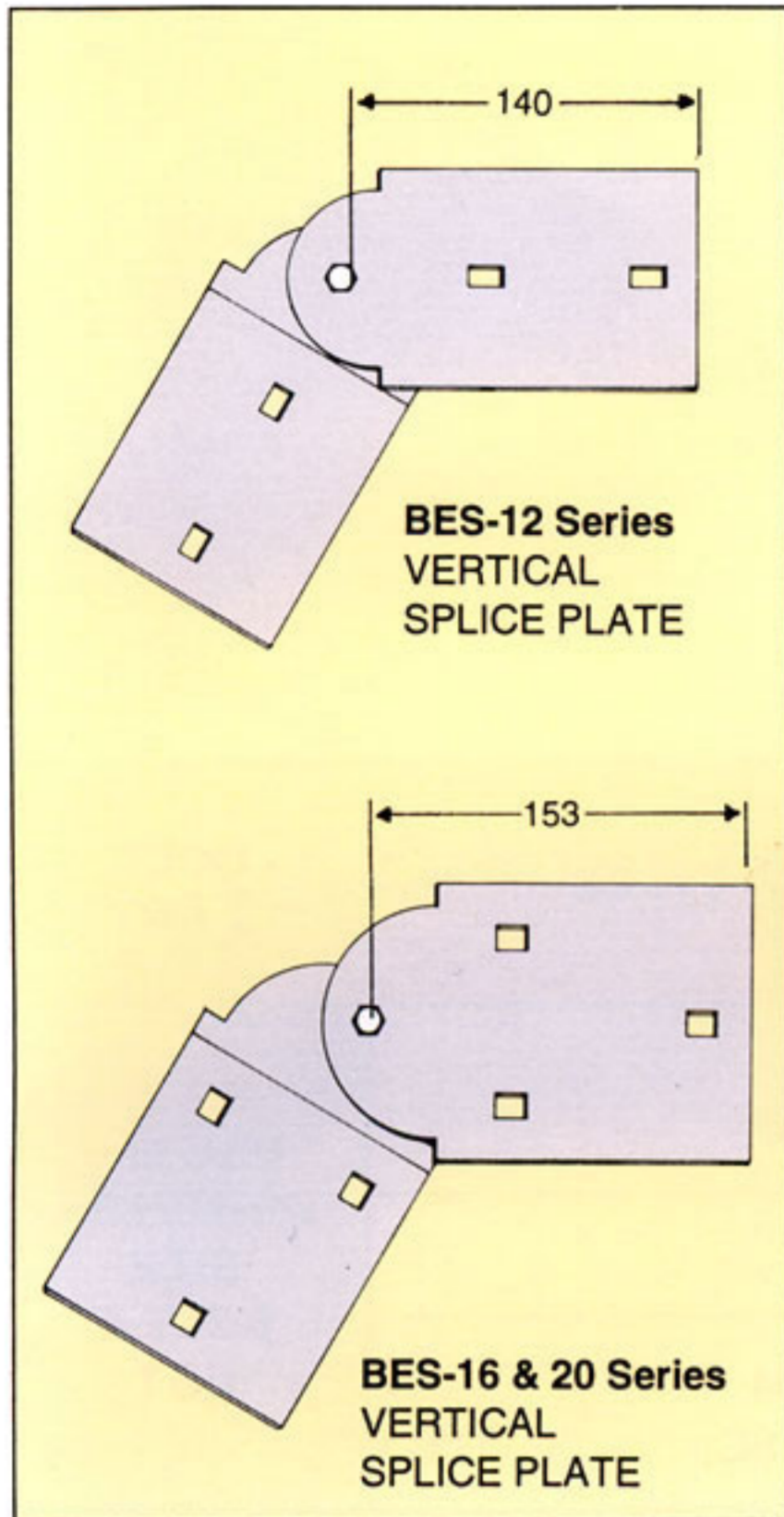

DESCRIPTION:

VERTICAL CONNECTION SPLICE PLATE

ORDERING PART NUMBERS

Type Materials and Part Nos.	BES-12 Series	BES-16 Series	BES-20 Series
Steel in Hot Dip Galv. finish	SVCP-12	SVCP-16	SVCP-20
Aluminium in Mill finish	AVCP-12	AVCP-16	AVCP-20
Stainless Steel 2B finish	SSVCP-12 - 304 SSVCP-12 - 316L	SSVCP-16 - 304 SSVCP-16 - 316L	SSVCP-20 - 304 SSVCP-20 - 316L

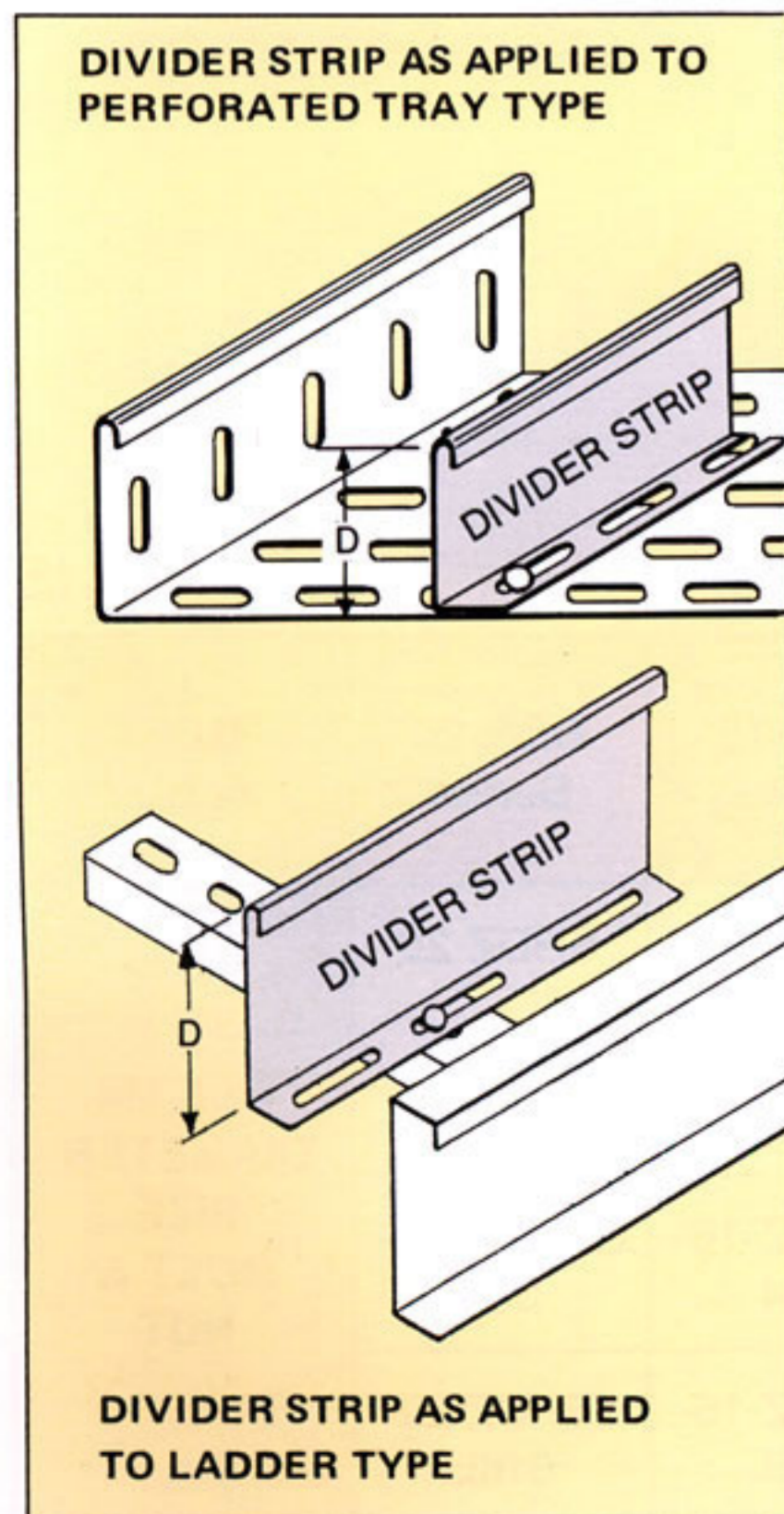

DESCRIPTION:

DIVIDER STRIP (APPLICABLE ALSO TO PERFORATED TRAYS)

ORDERING PART NUMBERS

Type Materials and Part Nos.	ALL LADDER & PERFORATED TYPE	D	Length
Steel in Hot Dip Galv. finish	SDS - 340 SDS - 365 SDS - 390 SDS - 3120	40mm 65mm 90mm 120mm	3M
Aluminium Mill finish	ADS - 340 ADS - 365 ADS - 390 ADS - 3120	40mm 65mm 90mm 120mm	3M
Stainless Steel 2B finish	SSDS - 340 SSDS - 365 SSDS - 390 SSDS - 3120	40mm 65mm 90mm 120mm	2.4M or 3.0M

CABLE LADDER ACCESSORIES...

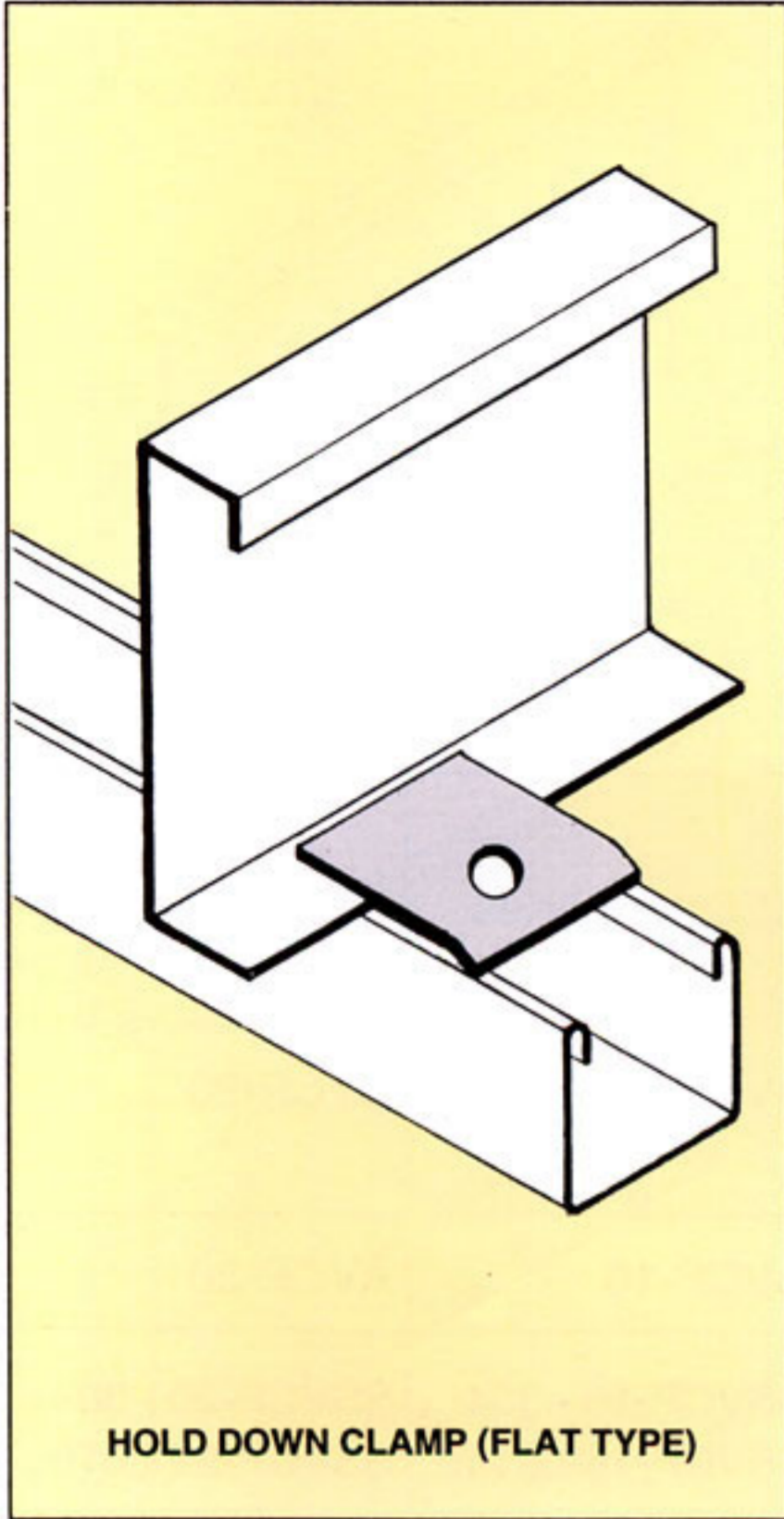

DESCRIPTION:

HOLD-DOWN CLAMP (FLAT TYPE)

ORDERING PART NUMBERS

Materials and Part Nos.	Type	ALL LADDER TYPES	BOLT & NUT
Steel in Hot Dip Galv. finish		SHDf-12	USE M 8 DIAMETER SIZE BOLT & NUT
Aluminium Mill finish		AHDf-12	
Stainless Steel 2B finish		SSHDF-12-304 SSHDF-12-316L	

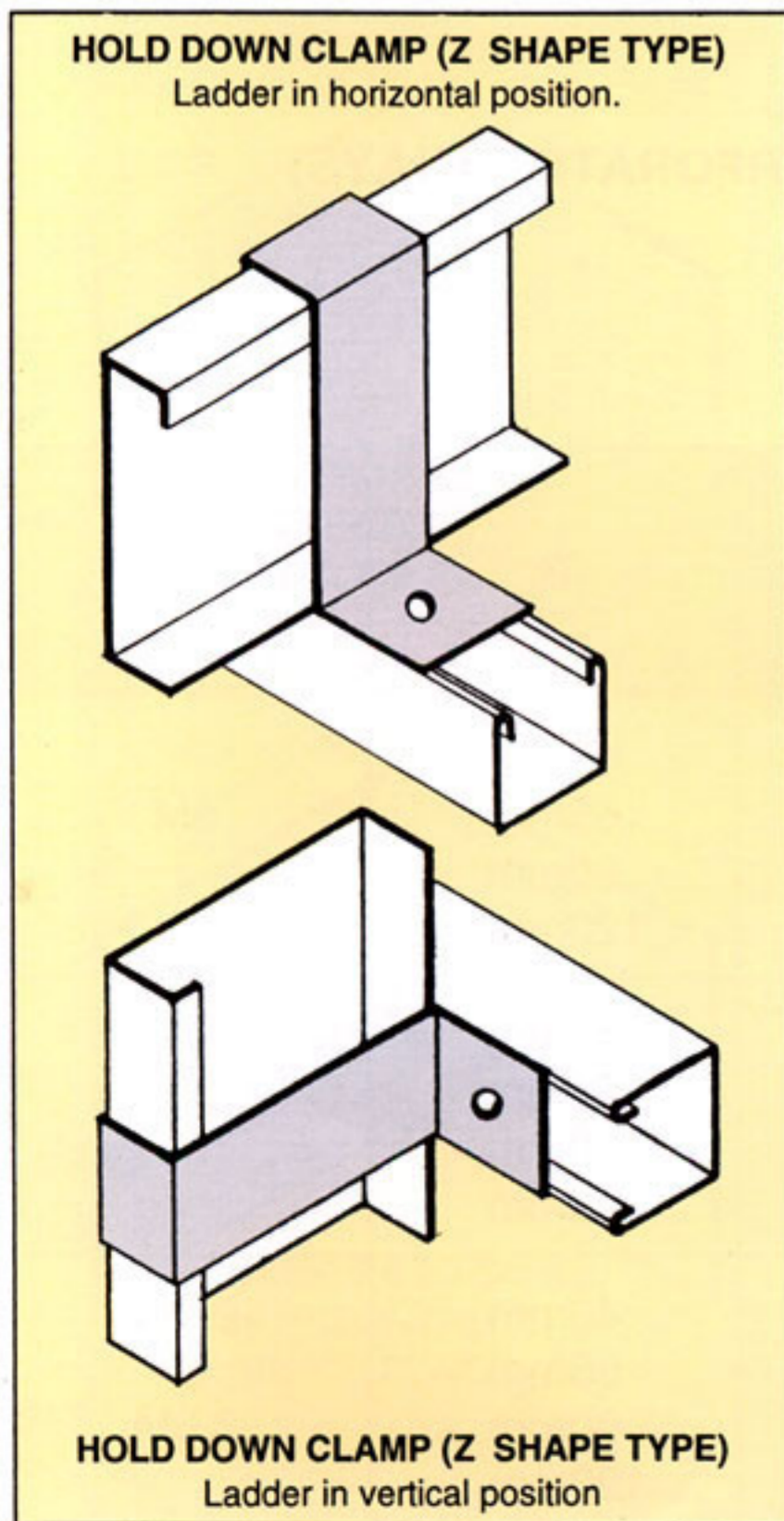

DESCRIPTION:

HOLD-DOWN CLAMP (Z SHAPE TYPE)

ORDERING PART NUMBERS

Materials and Part Nos.	Type	BES-12 Series	BES-16 Series	BES-20 Series	BOLT & NUT
Steel in Hot Dip Galv. finish		SHDZ-12	SHDZ-16	SHDZ-20	USE M8 DIAMETER SIZE BOLT & NUT
Aluminium Mill finish		AHDZ-12	AHDZ-16	AHDZ-20	
Stainless Steel AISI 304		SSHZ-12-304	SSHZ-16-304	SSHZ-20-304	
Stainless Steel AISI 316L		SSHZ-12-316L	SSHZ-16-316L	SSHZ-20-316L	