

BESstrut CHANNELS AND COMBINATIONS

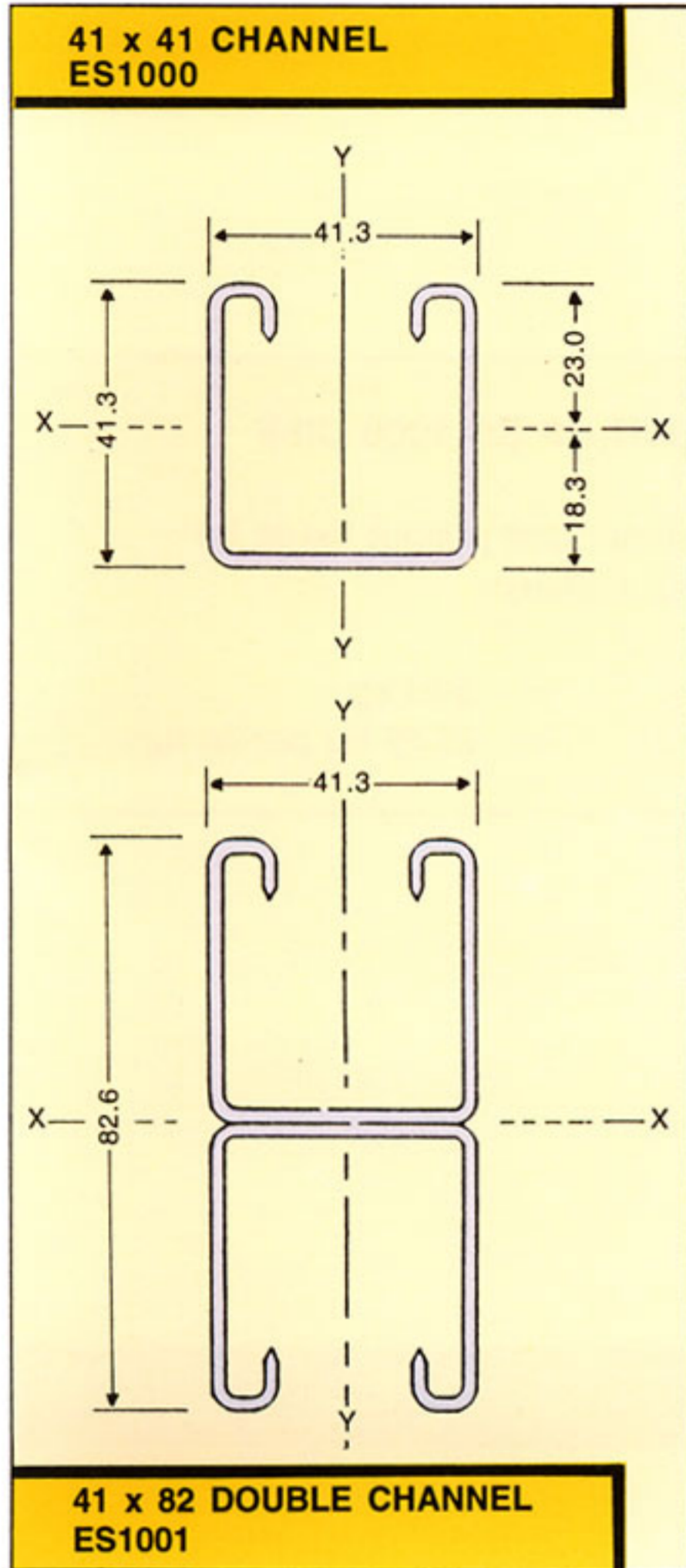

Length	6m
Wall Thickness	2.5mm
Finish:	a) Factory mill finish b) Hot dip galv. (HDG)

NOTE:

Thinner guage channels are available, on request.

ES 1000 - 16G	} 41 x 41 section	(1.6mm thick)
ES 1000 - 14G		(2.0mm thick)
ES 3300 - 16G	} 41 x 22 section	(1.6mm thick)
ES 3300 - 14G		(2.0mm thick)

Strength of ES1010-M12 Nut in ES1000 & ES3300 Channels:

Resistance to slip	=	680 kg
Pull out strength	=	900 kg
Safety factor	=	3

NOTE:

Stainless steel channels available on indent with minimum quantity of 500 lengths.

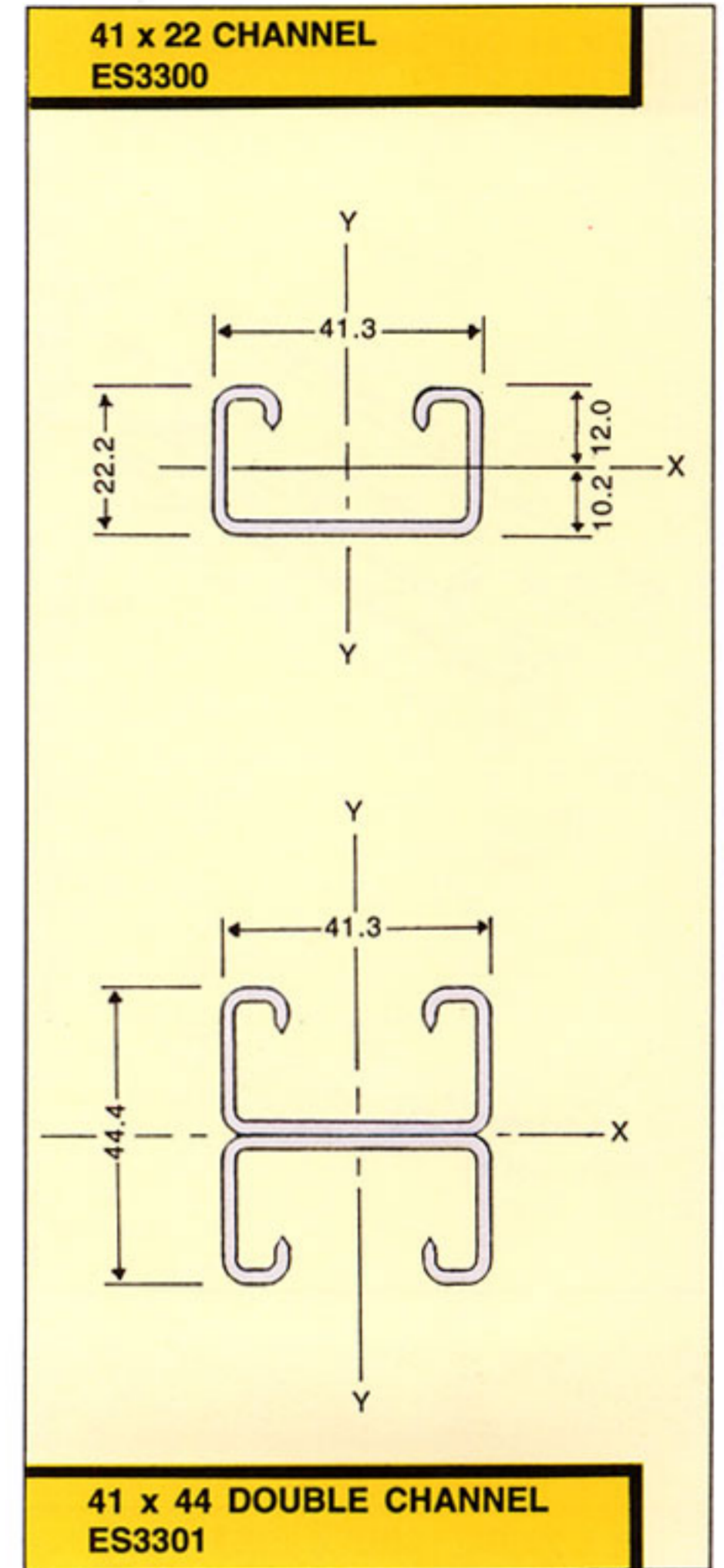

TECHNICAL DATA

Part Nos.	MASS (kg/m)	Area (mm ²)	AXIS X-X			AXIS Y-Y		
			I (10 ³ mm ⁴)	Z (10 ³ mm ³)	R (mm)	I (10 ³ mm ⁴)	Z (10 ³ mm ³)	R (mm)
ES 1000	2.68	335	74.98	3.26	14.83	94.35	4.57	16.63
ES 1001	5.36	670	378.03	9.15	23.54	186.00	9.00	16.70
ES 3300	1.92	242	15.02	1.17	7.84	57.98	2.81	15.40
ES 3301	3.84	484	71.23	3.24	12.07	116.00	5.67	15.60

I = Moment of inertia Z = Section Modulus R = Radius of gyration

BESstrut CONCRETE INSERTS

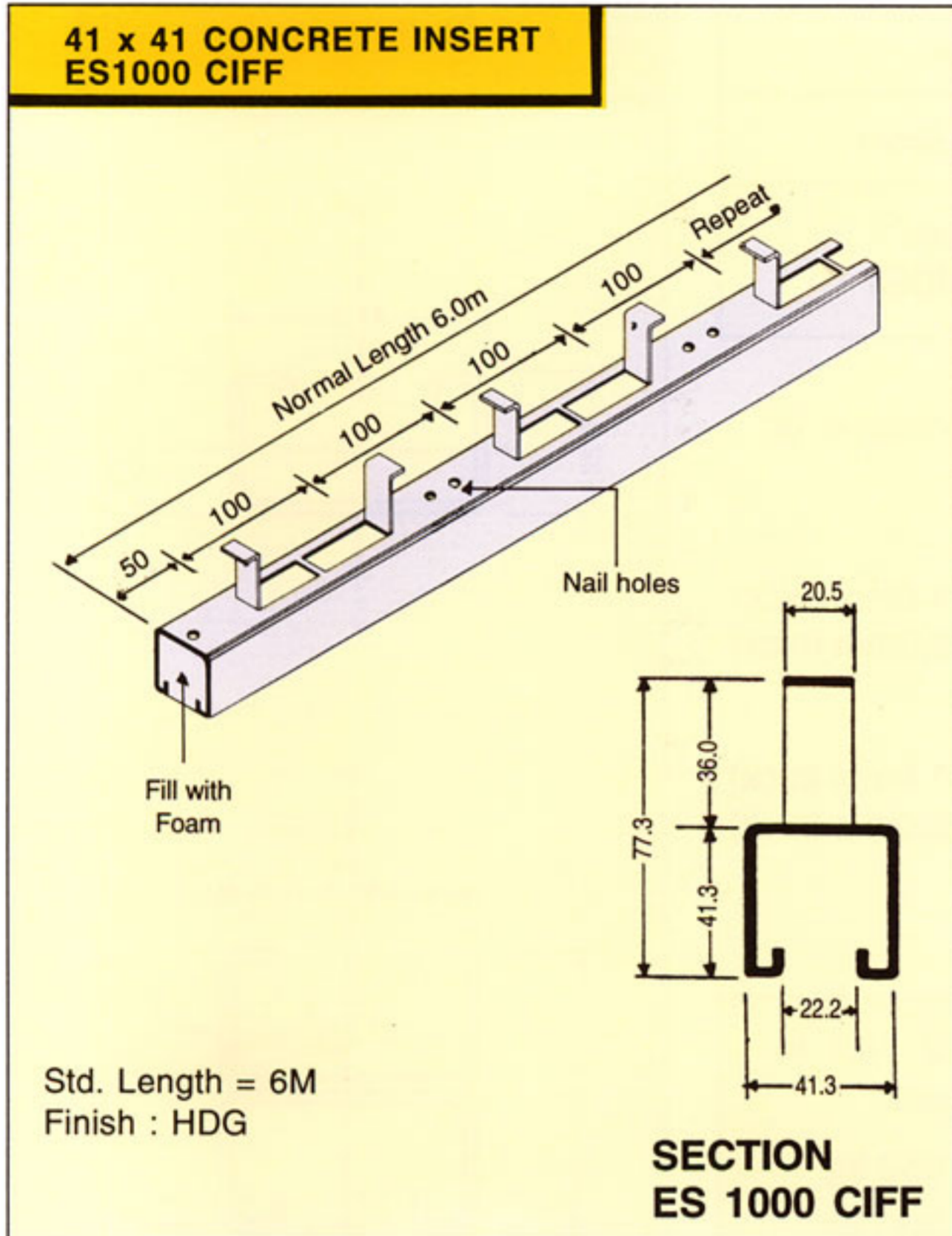

PULLOUT STRENGTH OF ES 1000 CIFF

The maximum recommended pullout loads for ES 1000 CIFF are as follows:-

200mm length	=	540 kg
3000mm length	=	2975 kg per m run.

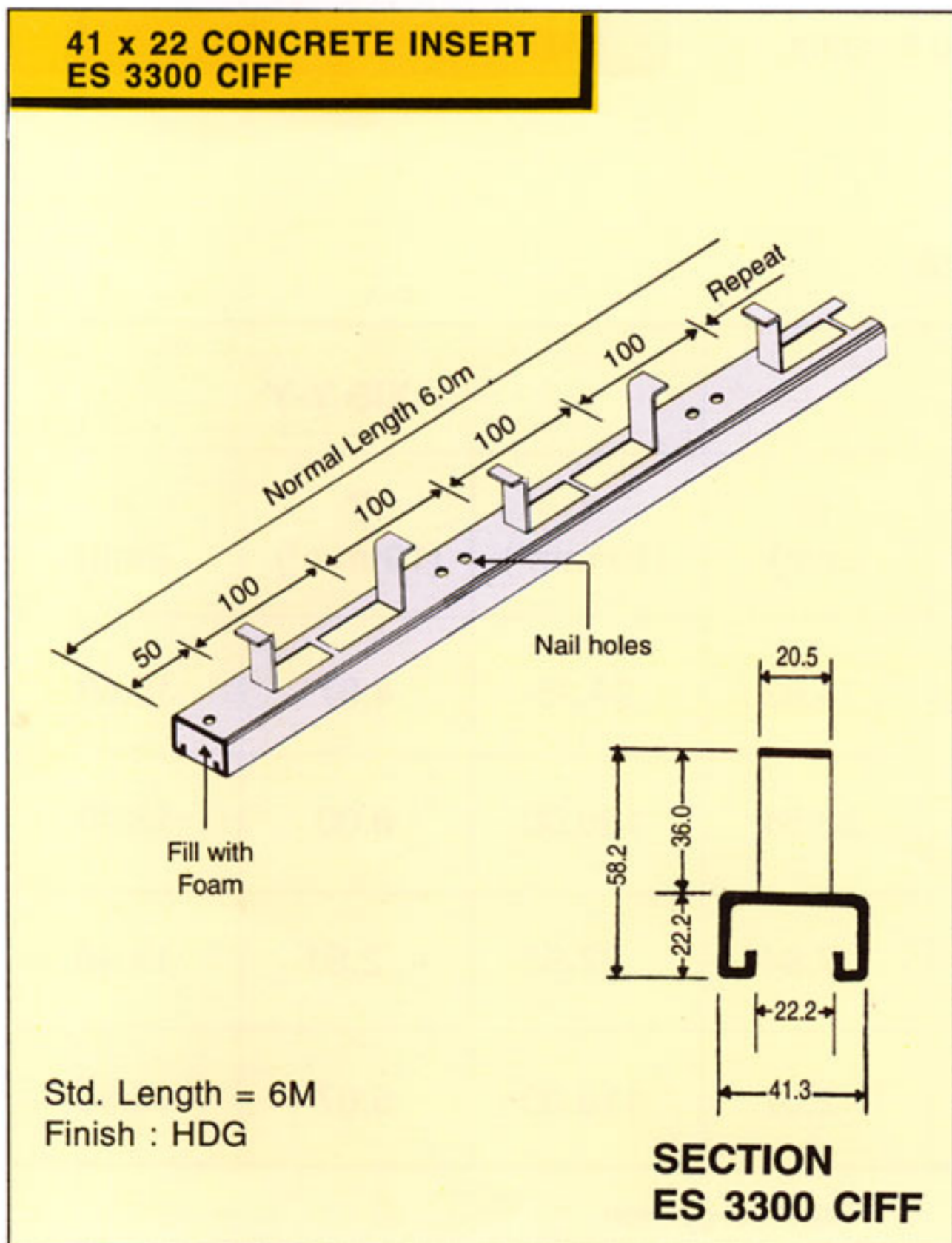

PULLOUT STRENGTH OF ES 3300 CIFF

The maximum recommended pullout loads for ES 3300 CIFF are as follows:-

200mm length	=	400 kg
3000mm length	=	2230 kg per m. run.

NOTE:
Minimum length of concrete insert shall be 200mm with 100mm increments. Safety factor = 3

SUPPORT BRACKETS

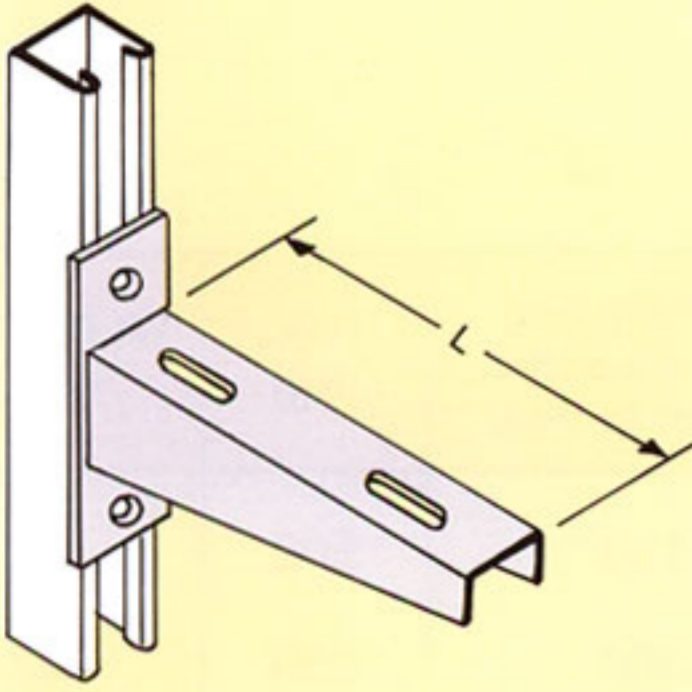

LIGHT DUTY CANTILEVER BRACKET, ES 2491 SERIES

PART NO.	L (mm)	Width of Ladder or Tray (W) (mm)	UDL (Kg)	Wt Per 100 (Kg)
ES 2491 - 10	250	100	500	26
ES 2491 - 15	300	150	500	38
ES 2491 - 25	400	250	300	68
ES 2491 - 30	450	300	250	96
ES 2491 - 45	600	450	180	118
ES 2491 - 55	700	550	150	180
ES 2491 - 60	750	600	136	250

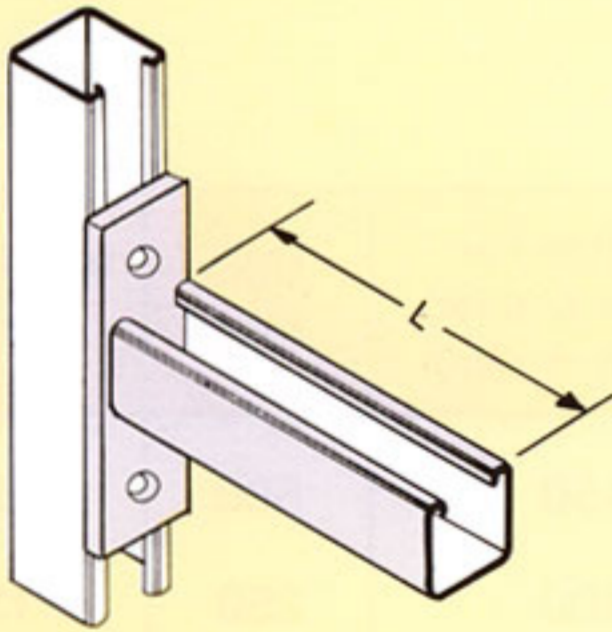

MEDIUM DUTY CANTILEVER BRACKET, ES 2663 SERIES

PART NO.	L (mm)	Width of Ladder or Tray (W) (mm)	UDL (Kg)	Wt Per 100 (Kg)
ES 2663 - 15	300	150	500	85
ES 2663 - 30	450	300	250	123
ES 2663 - 45	600	450	180	167
ES 2663 - 60	750	600	136	210

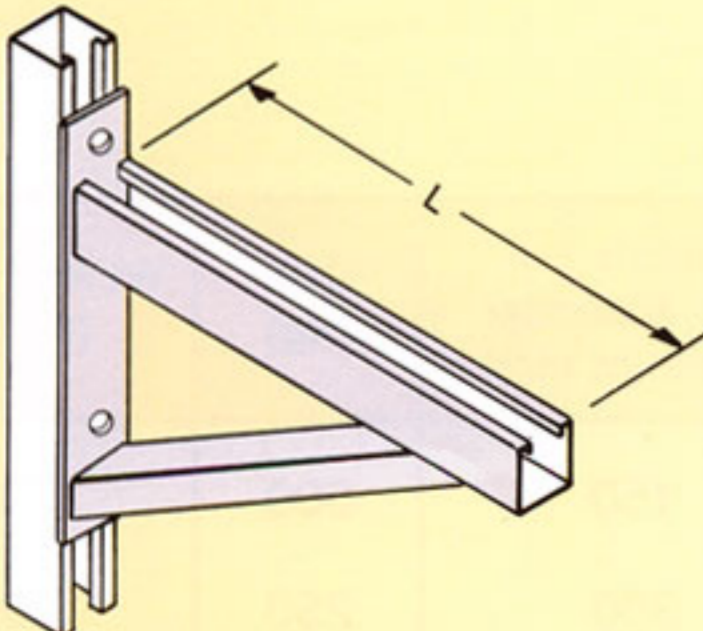

HEAVY DUTY CANTILEVER BRACKET, HCL SERIES

PART NO.	L (mm)	Width of Ladder or Tray (W) (mm)	UDL (Kg)	Wt Per 100 (Kg)
HCL 15	300	150	990	126
HCL 30	450	300	455	160
HCL 45	600	450	340	214
HCL 60	750	600	250	255
HCL 76	910	760	226	300
HCL 90	1050	900	136	343

SUPPORT BRACKETS

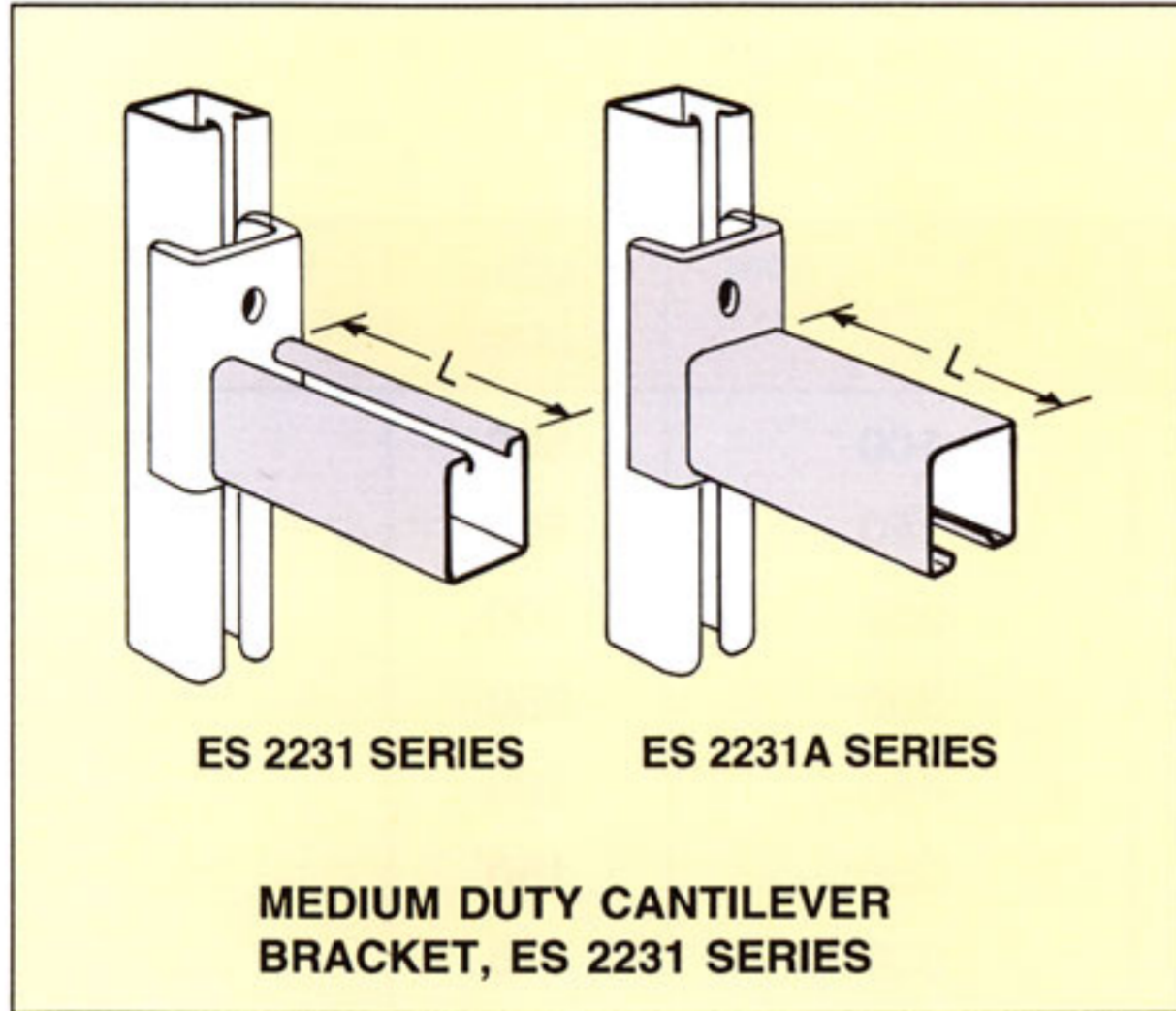

PART NOS.	L (mm)	Suitable For Tray & Ladder (Width in mm)	UDL (Kg)	Wt Per 100 (Kg)
ES 2231 - 15	300	150	500	82
ES 2231 - 30	450	300	250	122
ES 2231 - 45	600	450	180	159
ES 2231 - 60	750	600	136	206

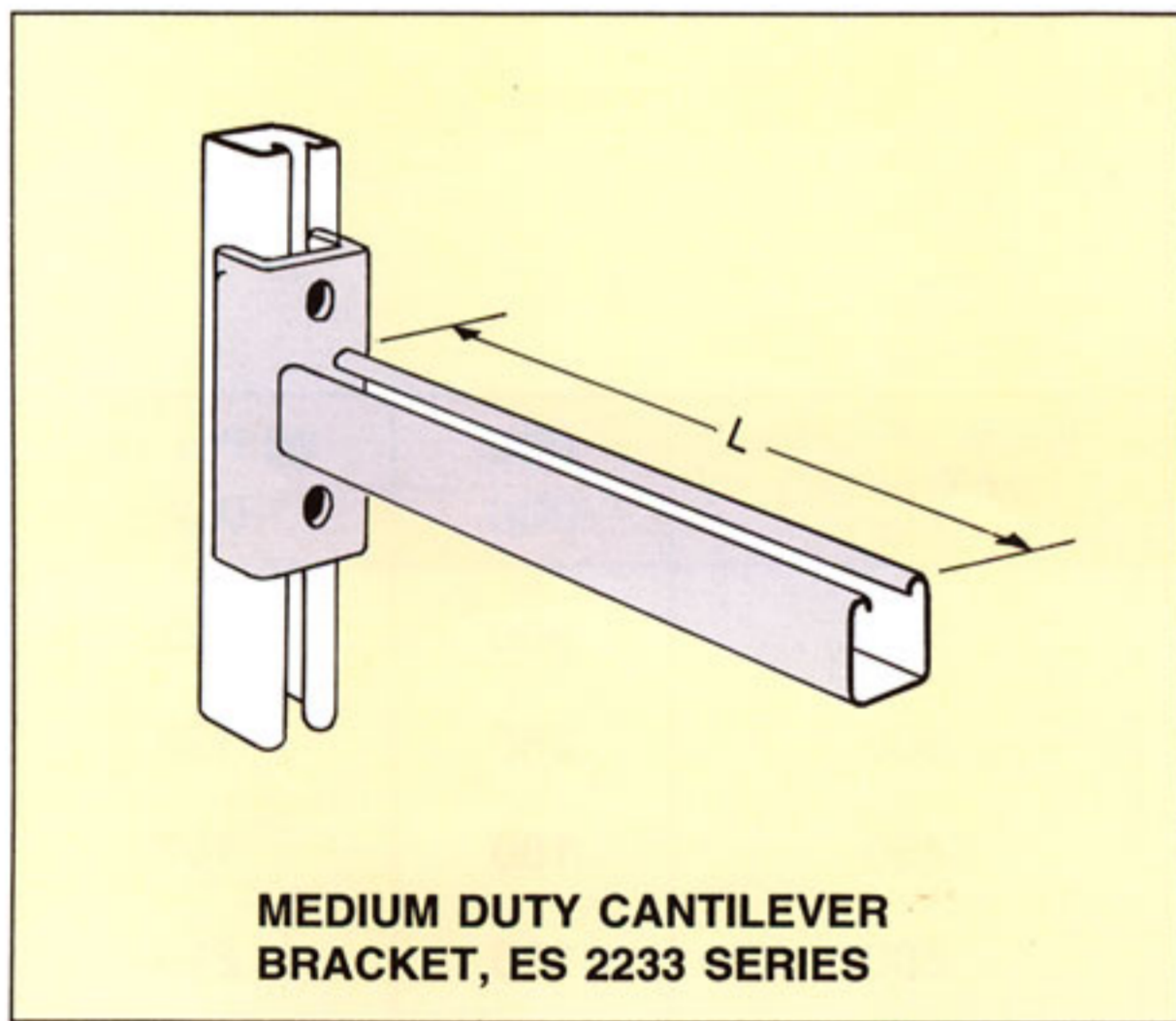

PART NOS.	L (mm)	Suitable For Tray & Ladder (Width in mm)	UDL (Kg)	Wt Per 100 (Kg)
ES 2233 - 15	300	150	500	92
ES 2233 - 30	450	300	250	132
ES 2233 - 45	600	450	180	178
ES 2233 - 60	750	600	136	230

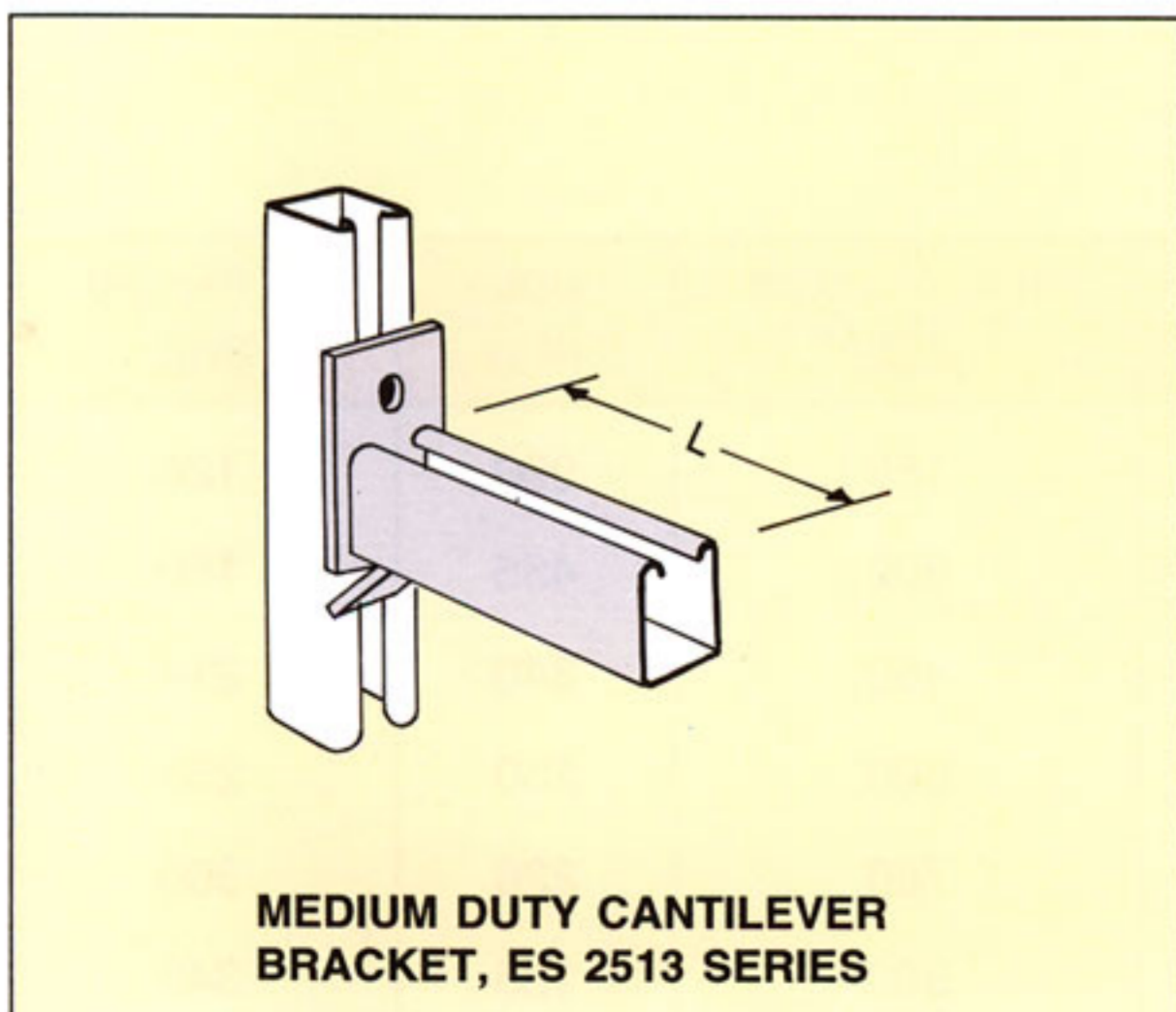

PART NOS.	L (mm)	Suitable For Tray & Ladder (Width in mm)	UDL (Kg)	Wt Per 100 (Kg)
ES 2513 - 15	300	150	500	75
ES 2513 - 30	450	300	250	119
ES 2513 - 45	600	450	180	165
ES 2513 - 60	750	600	136	210

BOLT AND NUTS

CASE HARDENED NUT FOR ES 1000 CHANNELS.

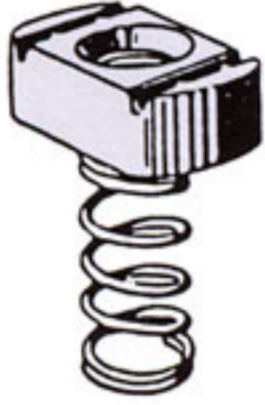

PART NO.	DIA
ES 1007 - M8	M8
ES 1008 - M10	M10
ES 1010 - M12	M12
finish: EZP	

CASE HARDENED NUT FOR ES 3300 CHANNELS



PART NO.	DIA
ES 4007 - M8	M8
ES 4008 - M10	M10
ES 4010 - M12	M12
finish: EZP	

CASE HARDENED NUT FOR ES 1000 & ES 3300 CHANNELS

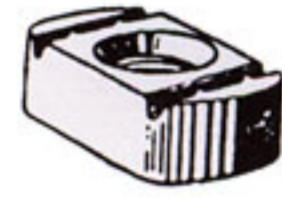

PART NO.	DIA
ES 3007 - M8	M8
ES 3008 - M10	M10
ES 3010 - M12	M12
finish: EZP	

FLAT NUT FOR ES 1000 & ES 3300 CHANNELS



PART NO.	DIA
ES 3016	M6
finish: EZP	

HEX. HEAD SET BOLT

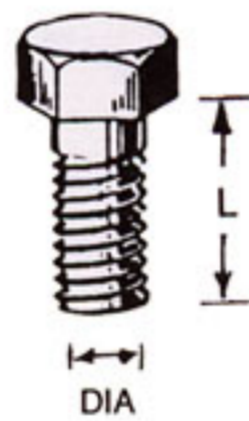

PART NO.	DIA	L
HHSB M6 x 20	M6	20
HHSB M6 x 25	M6	25
HHSB M8 x 20	M8	20
HHSB M8 x 25	M8	25
HHSB M8 x 30	M8	30
HHSB M10 x 25	M10	25
HHSB M10 x 30	M10	30
HHSB M10 x 40	M10	40
HHSB M12 x 25	M12	25
HHSB M12 x 30	M12	30
HHSB M12 x 40	M12	40
finish: EZP SS 304 SS 316		

HEX. NUT



PART NO.	DIA
HN M6	M6
HN M8	M8
HN M10	M10
HN M12	M12
finish: EZP SS 304 SS 316	

ROUND SLOTTED HEAD MACHINE SCREWS

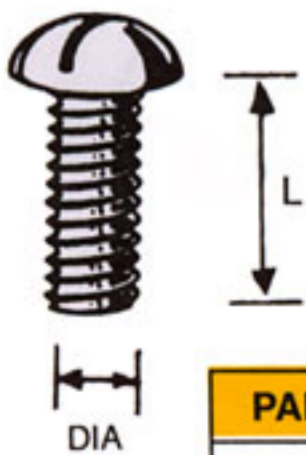

PART NO.	DIA	L
RHSS M6 x 20	M6	20
RHSS M6 x 25	M6	25
RHSS M8 x 20	M8	20
RHSS M8 x 25	M8	25
RHSS M8 x 30	M8	30
finish: EZP SS 304 SS 316		

ROUND FLAT WASHERS



PART NO.	DIA
RFW M6	M6
RFW M8	M8
RFW M10	M10
RFW M12	M12
finish: EZP SS 304 SS 316	

ROUND SPRING WASHERS



PART NO.	DIA
RSW M6	M6
RSW M8	M8
RSW M10	M10
RSW M12	M12
finish: EZP SS 304 SS 316	